



DR1000 | ROLLER SERIES

DR1000 | ROLLER SERIES

The DR1000 Series rollers are high performance products suited for residential or commercial sliding window & door applications.

Manufactured with an engineered polymer outer carriage housing and passivated zinc inner carriage, this adjustable roller offers superior corrosion resistance and durability.

The DR1000 roller provides great performance and is moulded with a high performance engineered polymer that gives superior load rating and cycle testing.



PRODUCT DETAILS

OUTER CARRIAGE	Engineered polymer
INNER CARRIAGE	Cast zinc passivated
TYRE	DR 71 high performance polymer with "ZZ" bearing and dust seal.
FINISH AVAILABLE	Black
MAX LOAD CAPACITY	50kg per carriage
CYCLE RATING	Tested to 30,000 cycles

FEATURES

- Fully adjustable carriage gives 10mm height adjustment
- Stainless steel adjusting screw and nut width away from the pivot centre
- Polymer roller with bearing
- Roller 'ZZ' bearing with ground precision bearing for corrosion free operation
- Passivated metal inner carriage

ADVANTAGES

- Suits aluminium, timber and UPVC sliding doors
- Outer carriage and internal assembly manufactured to withstand corrosive environments
- Recommended for sliding doors up to 100kg

DR400 | Packer

SUITS	DR1000 & DR1009
MATERIAL	Engineered polymer
ADDS	11.7mm per packer
PRODUCT CODE	9042186

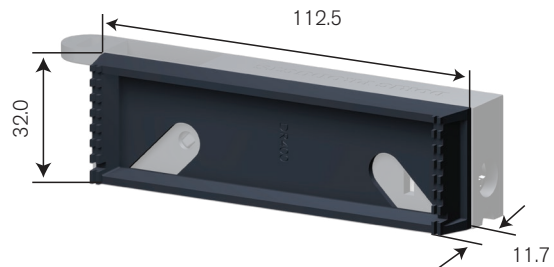

DR1000 | HEAVY DUTY DOUBLE ADJUSTABLE DOOR ROLLER

CARRIAGE	Engineered polymer outer Cast zinc passivated carriage
APPLICATION	Suitable for Aluminium Sliding Doors

ROLLER	WHEEL	WEIGHT RATING	ORDER CODE
Standard	DR71	50kg max load	9036686

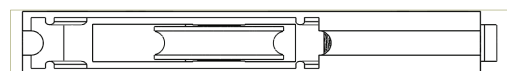
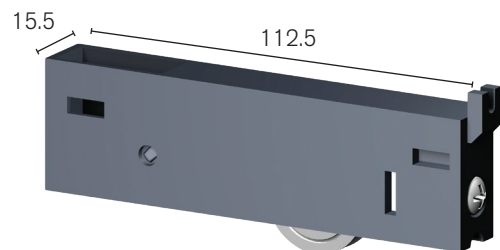

DR1001 | HEAVY DUTY DOUBLE ADJUSTABLE DOOR ROLLER

CARRIAGE	Engineered polymer outer Cast zinc passivated carriage
APPLICATION	Suitable for Aluminium Sliding Doors

ROLLER	WHEEL	WEIGHT RATING	ORDER CODE
Standard	DR71	50kg max load	9033973
Optional	DR2	20kg max load	9033971

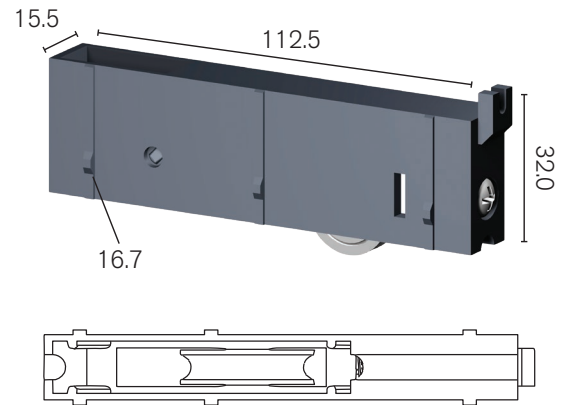

DR1003 | HEAVY DUTY DOUBLE ADJUSTABLE DOOR ROLLER

CARRIAGE	Engineered polymer outer Cast zinc passivated carriage
APPLICATION	Suitable for Aluminium Sliding Doors

ROLLER	WHEEL	WEIGHT RATING	ORDER CODE
Standard	DR71	50kg max load	9033980

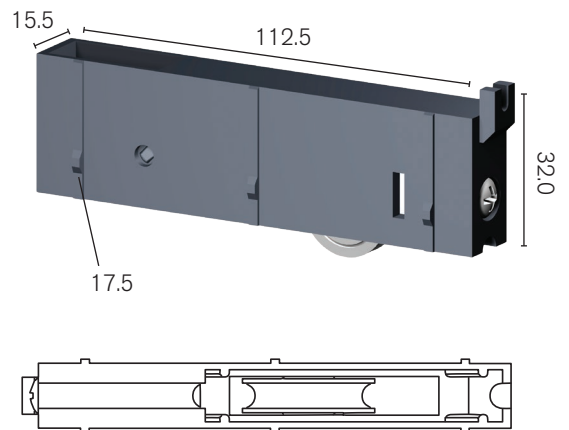

DR1009 | HEAVY DUTY DOUBLE TIMBER DOOR ROLLER

CARRIAGE	Engineered polymer outer Cast zinc passivated carriage
APPLICATION	Suitable for Timber Sliding Doors

ROLLER	WHEEL	WEIGHT RATING	ORDER CODE
Standard	DR71	50kg max load	9040456

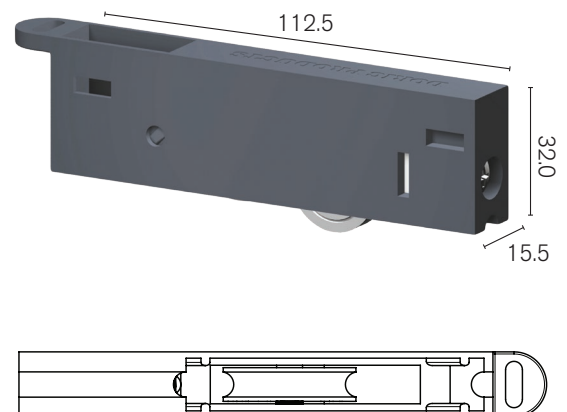

INNOVATORS

OF HARDWARE FOR WINDOWS AND DOORS

DR1000_SERIES_ROLLERS-v1.1-30.03.2021

SYDNEY

38 Redfern St,
Wetherill Park
Sydney, NSW 2164
Australia
Ph: +61 2 9609 2555
www.doric.com.au

AUCKLAND

26/C Triton Drive,
Albany, North Shore,
Auckland 0632
New Zealand
Ph: +64 9 415 5535
www.doric.co.nz

KUALA LUMPUR

No.17 Jalan 51/203A,
Kawasan Perindustrian Tiong Nam,
Seksyen 51, 46050 Petaling Jaya,
Selangor, Malaysia
Ph: +603 777 33 628
www.doric.com.my



DR1000 | ROLLER SERIES