

Installation Instructions - Multi Point

Cut the door stile to the dimensions given below to mount the handle:

Below the door centerline

Above the door centerline

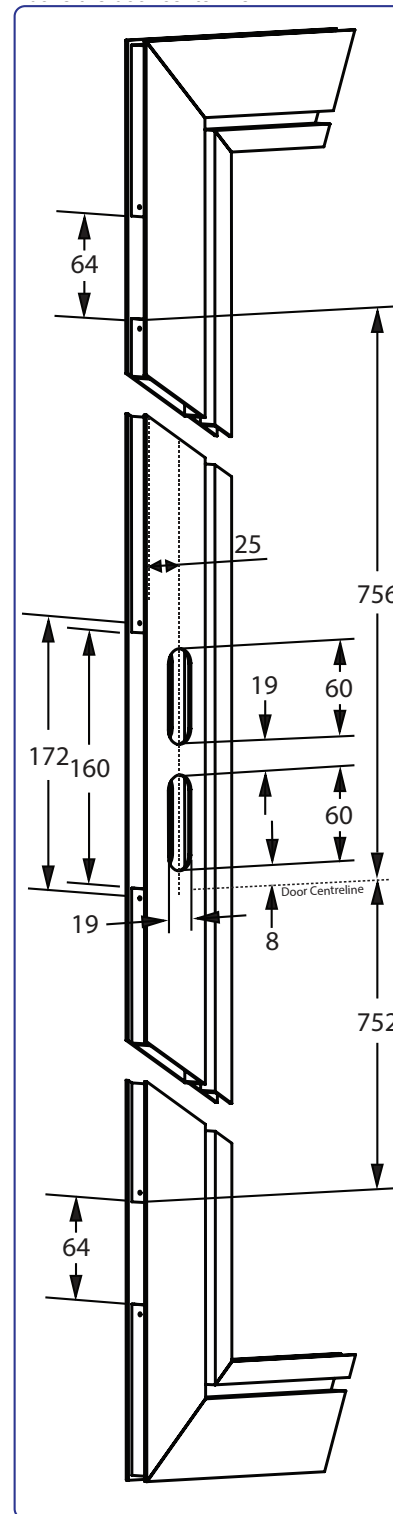
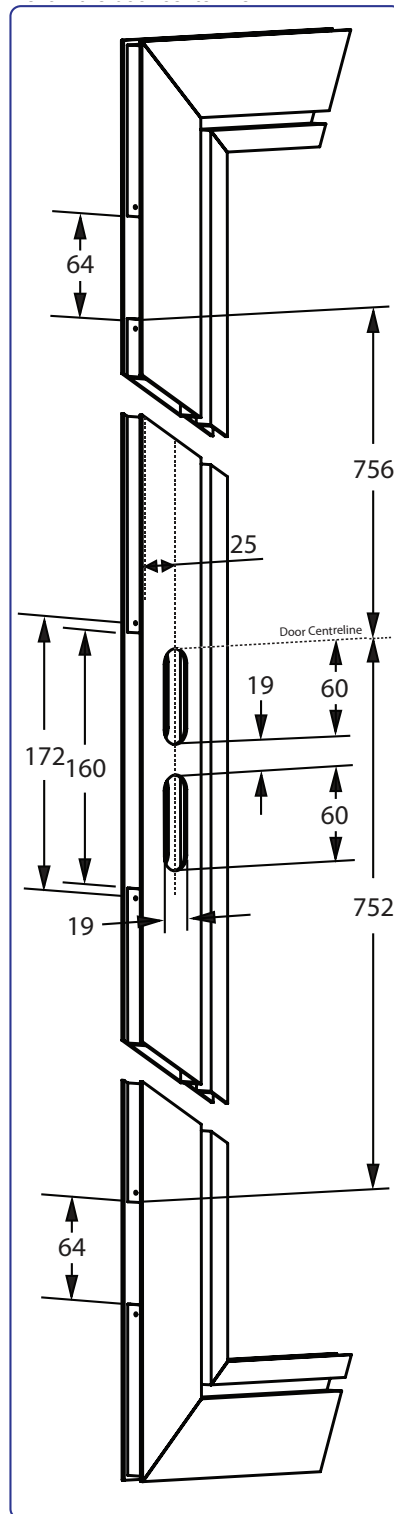
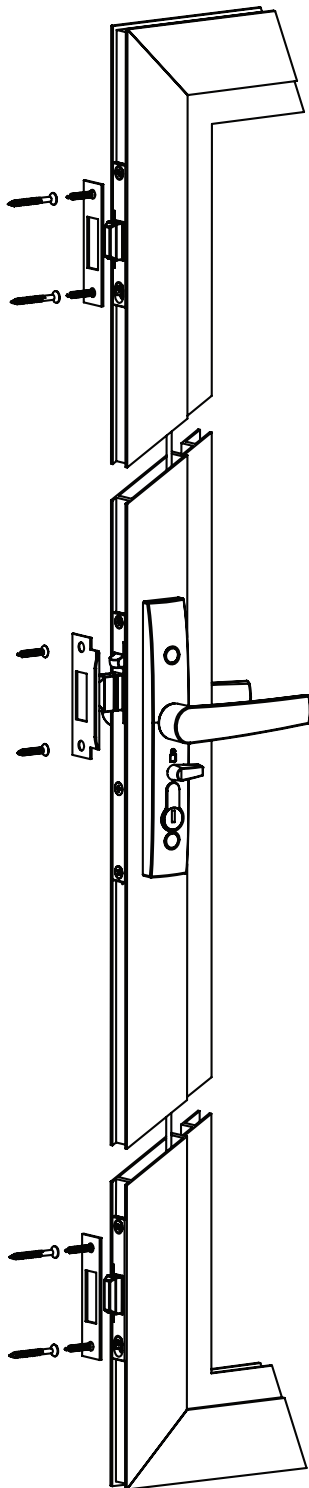

Extrusion Cut Outs

Assembling top and bottom locks to rods

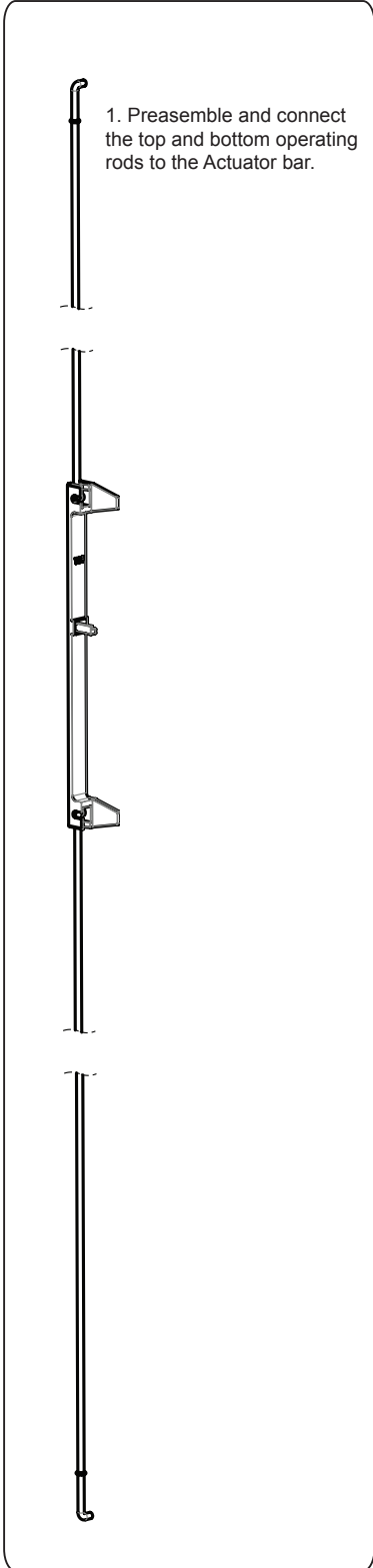

2. Feed the top and bottom operating rods fitted with the actuating bar through the the top cut. Do not fully insert slave locks into cutouts.
3. With the top slave unit in the locked position, attach the top rod.
4. Find and pull the bottom out through the bottom cutout.

