



OMEGA | DS5500
AWNING OPERATOR

OMEGA | DS5500 AWNING OPERATOR

Fastest awning operator on the market, with a smooth and effortless operation.

The Omega Awning Operator is another advanced solution from Doric to meet the growing trend of awning windows and push the boundaries of existing mechanisms.

Featuring a Push & Pull operation, the Omega improves access control by halving the time to open or close your awning windows.

Designed specifically to be adapted into residential applications, the Omega is available in either 90mm or 150mm arm lengths.

The 90mm arm has been designed to provide a restricted opening that complies with the NCC & "Kids Don't Fly" window restriction requirements.

ADVANTAGES



PUSH BUTTON MECHANISM

Unlike other operators, the push button mechanism improves functionality by halving the time to open or close an awning window.



PUSH & PULL OPERATION

Provides a smooth, effortless operation and control for awning windows.



WINDOW COMPATIBILITY

Available in both restricted & non-restricted openings to suit building requirements and ensure sufficient airflow.



'KIDS CAN'T FLY COMPLIANT'

90mm restricted option is compliant in association with ICP 005 "Window Prevention & Protection of Openable Windows".



KEYED & NON-KEYED

Available in either keyed or non-keyed options. Suitable with Doric's DS125, DS126 & Multi-Key wafer cylinders.



SAFE & SECURE

Cylinder drives hidden lock bar, which in turn locks off the push button mechanism to prevent tampering by children.

COLOURS



MOULDED
BLACK



MOULDED
SILVER



CUSTOM POWDER
COAT AVAILABLE

PRODUCT DETAILS

MATERIAL	Polesium™ Cover & Base, Polycarbonate Arm with SS 304 sash plate.
AVAILABLE FINISHES	Standard Moulded Colours STD & Non STD Powder coat
AVAILABLE LENGTHS	90mm arm (Restricted opening) 150mm arm (Full opening)

TESTING



CYCLE TEST

Functionality test according to ICP 002, completed & surpassed 10,000 operations



ULTIMATE TENSILE PULL TEST

Completed and surpassed 1452N



SHEAR LOAD TEST

Tested on handle in open position, completed and surpassed 10kg of force

OMEGA 90mm

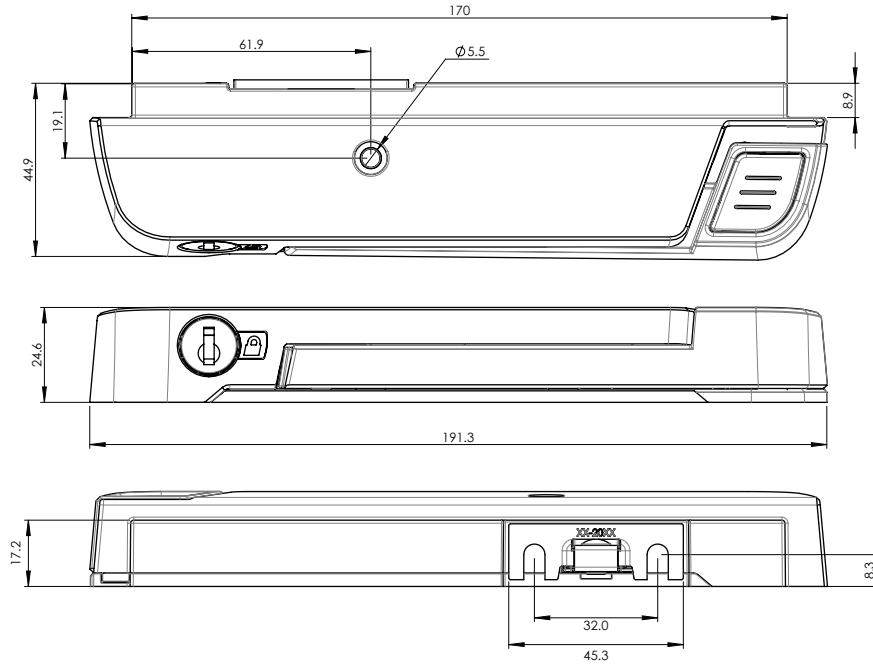

OMEGA 150mm

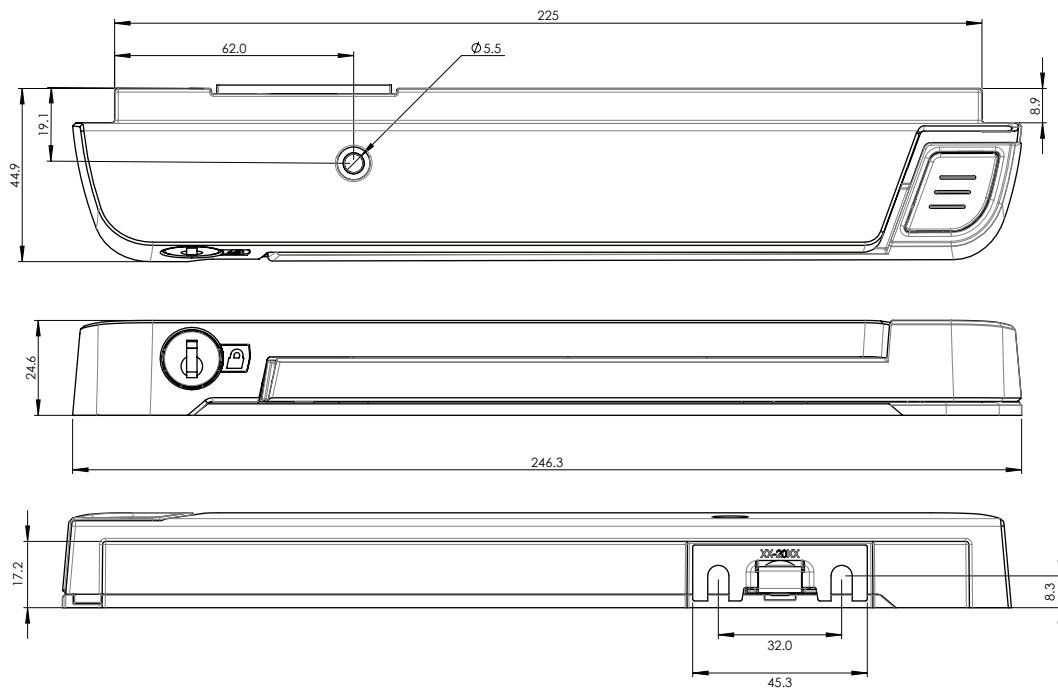

HOW TO ORDER

CODE	COLOUR	ARM LENGTH	CYLINDER & PLUG
MDS5500	Moulded Black Moulded Silver Custom (Powder coat)	90mm 150mm	DS125 DS126 DS127 DS515 Plug

INNOVATORS

OF HARDWARE FOR WINDOWS AND DOORS

OMEGA v1.4 - 10.08.2021

SYDNEY

38 Redfern St,
Wetherill Park
Sydney, NSW 2164
Australia
Ph: +61 2 9609 2555
www.doric.com.au

AUCKLAND

26/C Triton Drive,
Albany, North Shore,
Auckland 0632
New Zealand
Ph: +64 9 415 5535
www.doric.co.nz

KUALA LUMPUR

No.17 Jalan 51/203A,
Kawasan Perindustrian Tiong Nam,
Seksyen 51, 46050 Petaling Jaya,
Selangor, Malaysia
Ph: +603 777 33 628
www.doric.com.my



OMEGA | DS5500
AWNING OPERATOR