



SECURITY & BARRIER

**HARDWARE
& ACCESSORIES**

DS2075 | HINGED BARRIER SCREEN DOOR LOCK

SECURE PERFORMANCE WITHOUT QUESTION

Combines industry standard protection with durable and high quality craftsmanship for performance you can rely on.

Made from a diecast body with stainless steel strikes, the DS2075 provides Doric's highest level of security for all hinged screen doors.



**NON
HANDED
DESIGN**



**TESTED &
EXCEEDS AS4145
STANDARD**



**OPTIONAL DS2079
MULTI POINT KIT
AVAILABLE**



DS2210 | SLIDING BARRIER SCREEN DOOR LOCK

THE HIGH STANDARD FOR SLIDING BARRIER DOOR LOCKS

Featuring a self latching parrot beak deadlock and an inside snib, the DS2210 Sliding Barrier Screen Door Lock is a another high quality product from Doric.

The optional multi point slave kit increases protection for all sliding screen doors and offers value above and beyond what is currently available in the sliding screen door market.



**NON
HANDED
DESIGN**



**TESTED &
EXCEEDS AS4145
STANDARD**



**OPTIONAL DS2269
MULTI POINT KIT
AVAILABLE**



**AUSTRALIA'S BEST
& BIGGEST RANGE
OF WINDOW AND
DOOR HARDWARE**

For sales & information:
sales@doric.com.au
1300 132 389
www.doric.com.au



SECURITY & BARRIER HARDWARE & ACCESSORIES

HINGED BARRIER DOOR LOCKS

DS2075 Hinged Barrier Screen Door Lock	4
--	----------

SLIDING BARRIER DOOR LOCKS

DS2210 Sliding Barrier Screen Door Lock	6
---	----------

DS2220 Slimline Sliding Security Door Lock	8
--	----------

DS2200 Sliding Barrier Screen Door Lock	10
---	-----------

SLIDING BARRIER DOOR LATCH SET

DS2211 Sliding Screen Door Mortice Latch	12
--	-----------

SLAVE LOCKS | SLIDING BARRIER DOOR

DS2269 Slave Locks	13
----------------------	-----------

DS2266 Slave Locks	13
----------------------	-----------

DOOR CLOSER

DC224 Security Door Closer	14
------------------------------	-----------

DC223 Pneumatic Hinged Door Closer	15
--------------------------------------	-----------

CYLINDERS

DS196NSK Euro 62mm 5 Pin Cylinder	16
-------------------------------------	-----------

DS198 Euro 46mm 6 Wafer Cylinder	16
------------------------------------	-----------

ACCESSORIES

Security Door Hardware	17
------------------------	-----------

Security Door Hinges	18
----------------------	-----------

Sliding Security Door Hardware	19
--------------------------------	-----------

Fly Door Hardware	20
-------------------	-----------

Fly Screen Hardware	25
---------------------	-----------

FRINGE PILE

DP13 DP16 DP28	28
--------------------	-----------

SECURITY MESH

Security Mesh	29
---------------	-----------

SP67 SP70 SP90	30
--------------------	-----------

CMESH Stainless Steel Security Mesh	31
---------------------------------------	-----------

INSECT SCREEN

Insect Screen Range and Accessories	32
-------------------------------------	-----------

SECURITY PANELS

With Decorative Inserts	35
-------------------------	-----------

Colonial Classic Design	37
-------------------------	-----------

Floating Decorative Grilles	43
-----------------------------	-----------

DS2075 | HINGED BARRIER SCREEN DOOR LOCK

Doric's DS2075 Hinged Barrier Screen Door Locks combines industry standard protection with durable and high quality craftsmanship.

Made from a zinc die cast body with Stainless steel strikes, the DS2075 provides Doric's highest level of security for all hinged screen doors.

The optional multi point slave kit increases protection for all hinged screen doors and offers value above and beyond what is currently available in the hinged screen door market.

ADVANTAGES

- Non handed furniture - suits left handed and right handed doors
- Fits industry standard cut outs
- Zinc die cast lock mechanism and furniture
- Inside snib
- Accepts Doric Euro profile lazy cam cylinder
- Suit standard 20mm door thickness
- Tested and exceeds Australian and New Zealand AS4145 standard
- Optional DS2079 multi point slave kit available



PRODUCT DETAILS

APPLICATION	Suits hinged aluminium barrier screen doors
MATERIAL	Die cast zinc lock body
FINISHES	Powder coat
FIXINGS	Included

COLOURS



TESTING

- Tested & exceeds requirements for Australian & New Zealand AS4145 Standards

HOW TO ORDER

CODE	FINISH	CYLINDER	SLAVE KIT
MDS2075	Satin Black Pearl White Primrose	DS196NSK DS198	DS2079 (optional)

CYLINDER OPTIONS



DS196NSK
Euro 62mm
5 Pin C4



DS198
Euro 46mm
6 Wafer Cylinder



DIMENSIONS

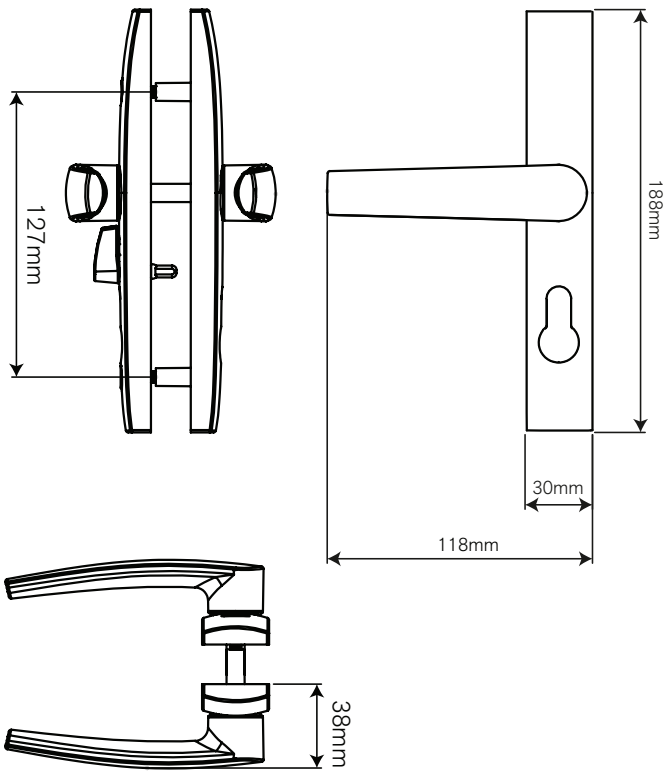

DS2079 | SLAVE LOCKS

Three point kit for DS2075 Hinged Barrier door lock consists of 2 slaves, 2 rods & saddle. The DS2079 suits all standard industry cut outs and can easily be retrofitted to existing openings.

APPLICATION	Suits DS2075
MATERIAL	Zinc and Stainless steel
FINISHES	Powder coat
INCLUSIONS	Slaves, keepers and fixings
ORDER CODE	MDS2079

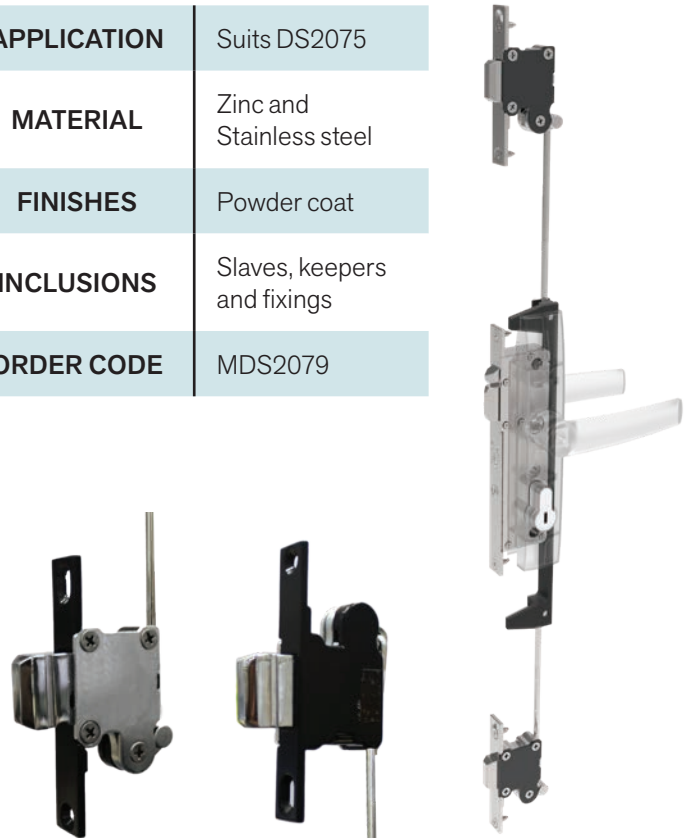

DS2210 | SLIDING BARRIER SCREEN DOOR LOCK

The DS2210 Sliding Screen Door Lock features a parrot beak deadlock and an inside snib. The DS2210 is self latching and can be key deadlocked from both sides.

The optional multipoint slave kit increases protection for all sliding screen doors and offers value above and beyond what is currently available in the sliding screen door market.

ADVANTAGES

- Suits either Left or Right hand closing sliding doors
- Parrot beak deadlock
- Key deadlock from both sides
- Self latching
- Key overrides snib operation
- Accepts Doric Euro profile lazy cam cylinder locks and compatible with other cylinders
- Optional Multi Point kits available
- Zinc diecast furniture and locking mechanisms



PRODUCT DETAILS

APPLICATION	Suits sliding aluminium barrier screen doors
MATERIAL	Die cast zinc lock body
FINISHES	Powder coat
FIXINGS	Included

COLOURS



TESTING

- Tested & exceeds requirements for Australian & New Zealand AS4145 Standards

HOW TO ORDER

CODE	FINISH	CYLINDER	SLAVE KIT
MDS2210	Satin Black Pearl White Primrose	DS196NSK DS198	DS2269 (optional)

CYLINDER OPTIONS



DS196NSK
Euro 62mm
5 Pin C4



DS198
Euro 46mm
6 Wafer Cylinder



DIMENSIONS

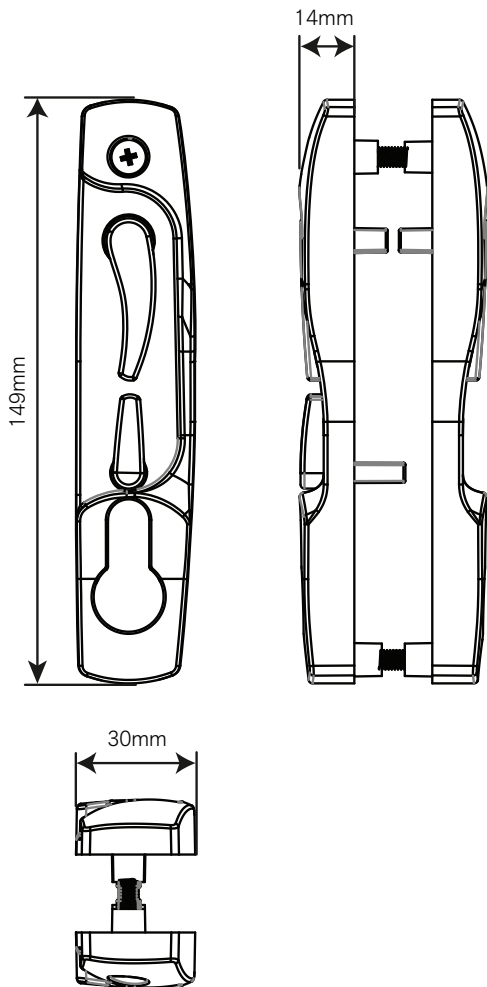

DS2269 | SLAVE LOCKS

Three point kit for the DS2210 Sliding Barrier door lock consists of two slaves, connecting rods & accessories.

The DS2269 suits all standard industry cut outs and can easily be retrofitted to existing openings.

APPLICATION	Suits DS2210
MATERIAL	Zinc and Stainless steel
FINISHES	Powder coat
INCLUSIONS	Slaves, keepers and fixings
ORDER CODE	MDS2269



DS2220 | SLIMLINE SLIDING SECURITY DOOR LOCK

The DS2220 Slimline Sliding Security Door Lock offers a clear point of difference to the Security market.

The DS2220 uses Stainless steel and Chrome plated components that provide the end-user with security, protection and reliability.

The addition of the DS2266 three point slave kit increases the level of security and offers added value above & beyond what is currently available in the Sliding Security door market.

ADVANTAGES

- Slimline designed aesthetics
- 2 point locking providing premium security level
- Stainless steel deadlocking pin and keeper components
- Patented throw bolt connecting rod system
- Non handed furniture



PRODUCT DETAILS

APPLICATION	Suits sliding aluminium barrier screen doors
MATERIAL	Zinc and Stainless steel
FINISH	Powder coat
CYLINDER	DS196NSK

COLOURS



TESTING

- Tested and Complies with Australian Standards for Security Door Systems: AS2803 : 1999; AS5039; AS5041

CYLINDER OPTIONS



DS196NSK
Euro 62mm
5 Pin C4

HOW TO ORDER

CODE	FINISH	CYLINDER	SLAVE KIT
MDS2220	Satin Black Custom on Request	DS196NSK	DS2266 (optional)



DIMENSIONS

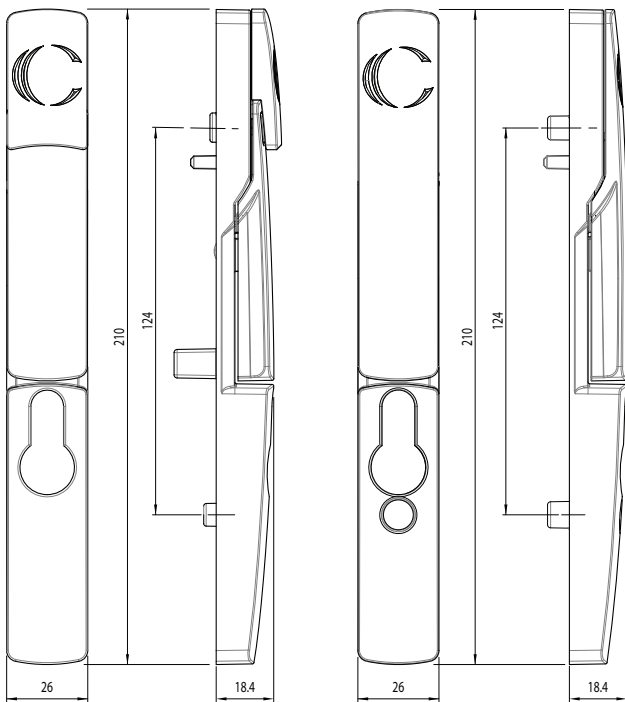

INTERNAL FURNITURE

EXTERNAL FURNITURE

DS2266 | SLAVE LOCKS

3 point kit for the DS2220 Sliding Barrier door lock consists of 2 slaves, 1 rod & accessories.

The DS2266 suits all standard industry cut outs and can easily be retrofitted to existing openings.

MATERIAL	Polesium™, zinc and Stainless steel
FINISHES	Bright chrome plated
INCLUSIONS	2 x DS2266 slaves 1 x DS2061 rod All keepers and fixings
ORDER CODE	MDS2266



DS2200 | SLIDING BARRIER SCREEN DOOR LOCK

The DS2200 Sliding Barrier Screen Door Lock features a internal beak deadlock, independent latch system and can be key deadlocked from both sides.

The optional multipoint slave kit increases protection for all sliding barrier doors.

ADVANTAGES

- Suits both right and left hand doors
- Unique Polesium™ corrosion free furniture
- Patented easy fit multi-point system
- Twin point locking
- Chrome plate lock body and keeper, corrosion resistant
- Independent latch system
- Stainless steel keeper and tongues
- Suits 160mm cut out



PRODUCT DETAILS

APPLICATION	Suits sliding aluminium security screen doors
MATERIAL	Polesium™, Die cast zinc lock body, Stainless steel tongue
FINISHES	Black Mill Powdercoat colours
FIXINGS	Included

COLOURS



SATIN BLACK



MILL BLACK

TESTING

- Exceeds Australian and New Zealand standard AS2803: 1999

CYLINDER OPTIONS



DS196NSK

Euro 62mm
5 Pin C4

HOW TO ORDER

CODE	FINISH	CYLINDER	SLAVE KIT
MDS2200	Satin Black	DS196NSK	DS2266 (optional)



DIMENSIONS

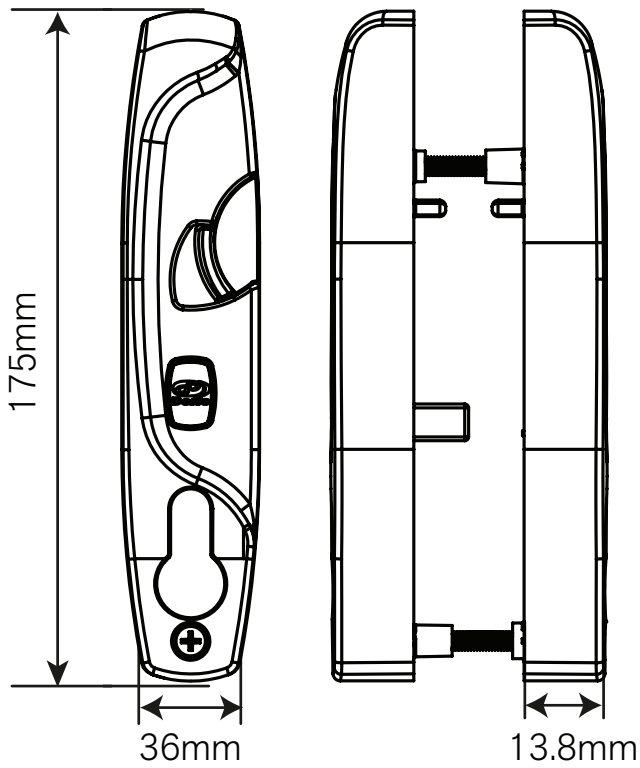

DS2266 | SLAVE LOCKS

3 point kit for the DS2200 Sliding Barrier door lock consists of 2 slaves, 1 rod & accessories.

The DS2266 suits all standard industry cut outs and can easily be retrofitted to existing openings.

APPLICATION	Suits DS2200
MATERIAL	Polesium™, zinc and Stainless steel
FINISHES	Bright chrome plated
INCLUSIONS	Slaves, keepers, 1x rod and fixings
ORDER CODE	MDS2266



DS2211 | SLIDING SCREEN DOOR MORTICE LATCH

The DS2211 Sliding Screen Door Mortice Latch features a self latching parrot beak mechanism. The DS2211 is the non-keyed version of the Doric's DS2210 Sliding Door Lock, and has been designed to securely latch sliding barrier screens doors shut where they don't need to be securely locked.

ADVANTAGES

- Suits left and right hand closing sliding doors
- Parrot beak deadlock
- Self latching
- Zinc die cast furniture and locking mechanisms
- Suits 160mm cut out

PRODUCT DETAILS

APPLICATION	Suits sliding aluminium barrier screen doors
MATERIAL	Die cast zinc lock body
FINISHES	Powder coat
FIXINGS	Included

COLOURS



SATIN BLACK

TESTING

- Tested & exceeds requirements for Australian & New Zealand AS4145 Standards

HOW TO ORDER

CODE	FINISH
MDS2211	Satin Black



DIMENSIONS

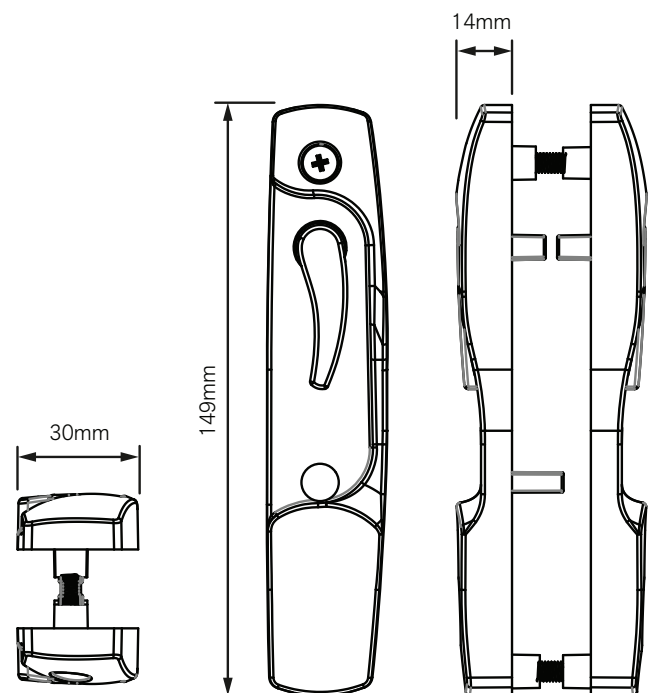

SLAVE LOCKS | SLIDING BARRIER SCREEN DOOR LOCKS

DS2269 | SLAVE LOCKS

3 point kit for the DS2210 Sliding Barrier Door Lock consists of 2 slaves, connecting rods & accessories.

The DS2269 suits all standard industry cut outs and can easily be retrofitted to existing openings.

PRODUCT DETAILS

APPLICATION	Suits DS2210
MATERIAL	Zinc and Stainless steel
FINISHES	Powder coat Black
FIXINGS	Included
INCLUSIONS	Pack includes slaves, keepers and all fixings
ORDER CODE	MDS2269

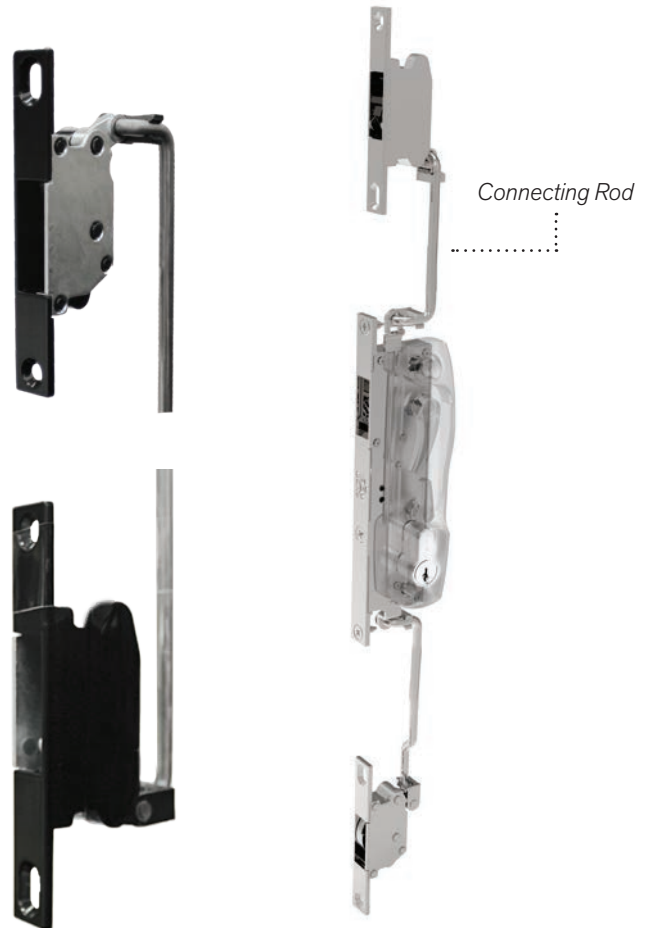

DS2266 | SLAVE LOCKS

3 point kit for the DS2200 & DS2220 Sliding Barrier Door Lock consists of 2 slaves, 1 rod & accessories.

The DS2266 suits all standard industry cut outs and can easily be retrofitted to existing openings.

PRODUCT DETAILS

APPLICATION	Suits DS2200 and DS2220
MATERIAL	Polesium™, zinc and Stainless steel
FINISHES	Bright chrome plated
FIXINGS	Included Allen key: DS2055
INCLUSIONS	DS2266 pack includes: 2 x DS2266 slaves 1 x DS2061 rod All keepers and fixings
ORDER CODE	MDS2266

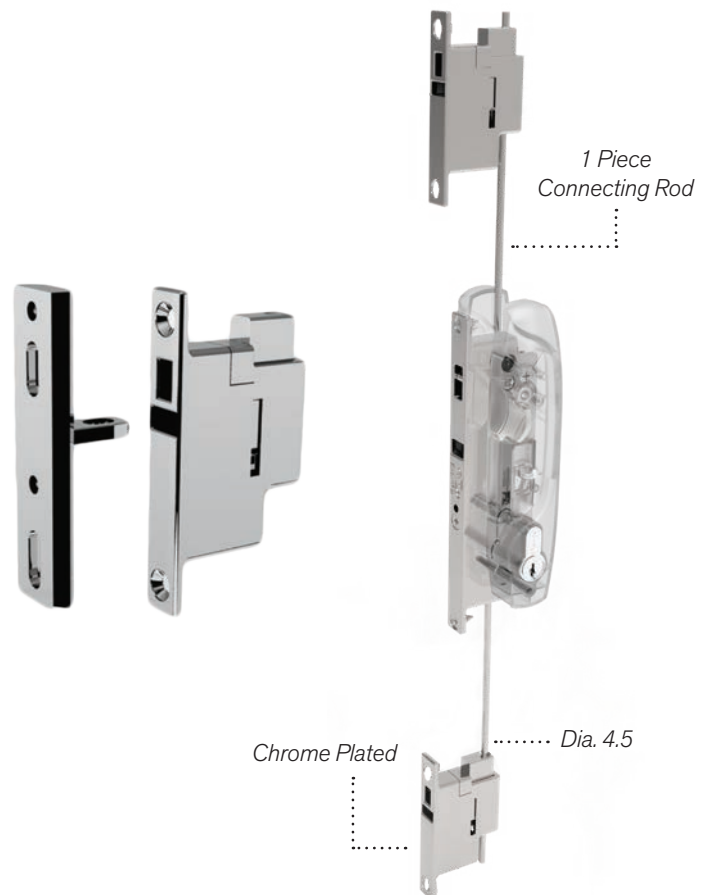

DC224 | SECURITY DOOR CLOSER



FEATURES

- Hold Open push button simplifies the locking hold process. Simply push the door further open to release the hold
- Secure fixing nut. Ensures the closer cannot pop out of the mounting bracket
- Adjustment screw to change the force required for different weights of doors.



ENGAGE HOLD OPEN
Click the button in, and open the door. Door will rest back and hold.



RELEASE HOLD
Open door further to release hold. Door can now close.

PRODUCT DETAILS

BODY MATERIAL	Extruded aluminium
FIXINGS MATERIAL	Powder coated mild steel
FINISH	Powder coat

COLOURS



TESTING

- Tested to 24kg
- Tested to 50,000 cycles

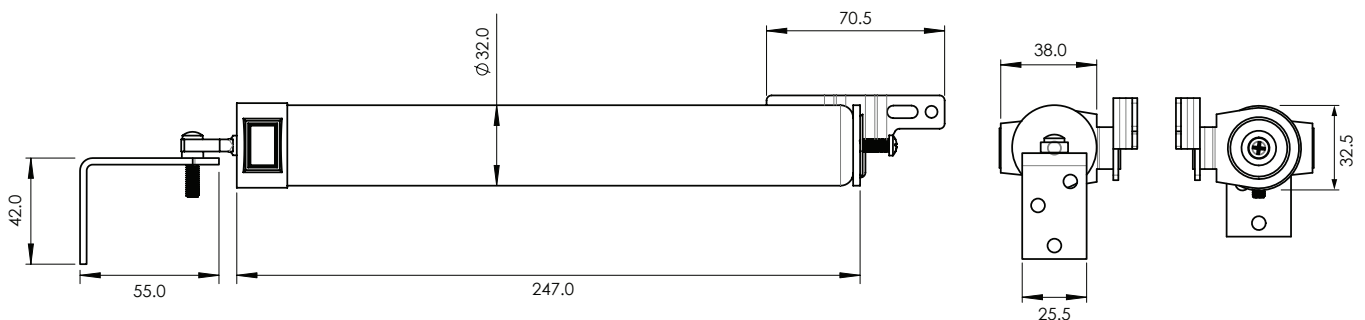

HOW TO ORDER

CODE	COLOUR	ORDER NO.
DC224	Black	9051784



See the DC224
in action

**WATCH THE
VIDEO:**



DC223 | PNEUMATIC HINGED DOOR CLOSER

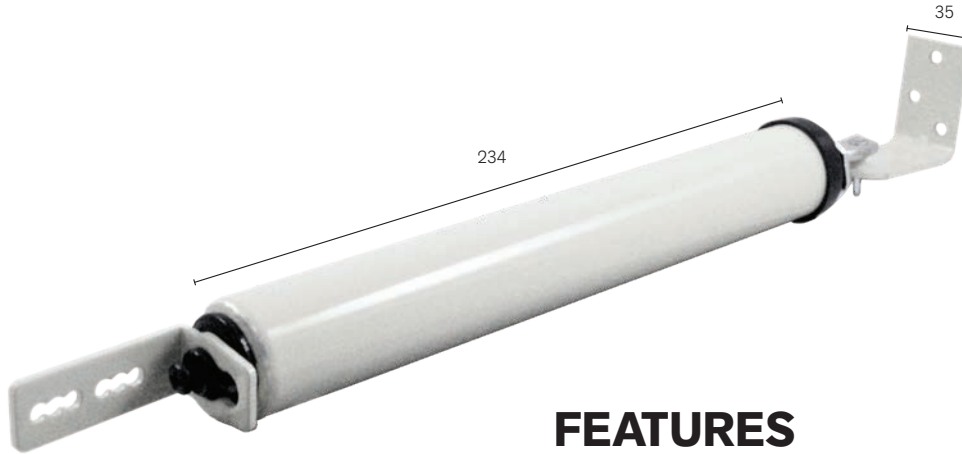

FEATURES

- Adjustment screw to change the force required for different weights of doors.
- Hold Open bracket
- Includes all brackets and screws

PRODUCT DETAILS

APPLICATION	For hinge flyscreen and hinge security screen doors
BODY MATERIAL	Extruded aluminium
FINISH	Powder coat
FIXINGS	All brackets and screws included

COLOURS



HOW TO ORDER

ORDER CODE	COLOUR	ORDER NO.
DC223	Black	9000150
DC223	White	9002695
DC223	Primrose	9003540

CYLINDERS | SECURITY DOOR LOCKS

DS196NSK | EURO 62MM 5 PIN CYLINDER WITH SPECIAL FUNCTION CAM - C4 KEYWAY

APPLICATION	Suits all sliding and swing door security locks
MATERIAL	Zinc/Brass
FINISHES	Chrome plated
CAM	Lazy/Floating
FIXINGS	M5 x 30mm (Included)
KEYING	#960 ** - Includes 2 keys
ORDER CODE	MDS196NSK /(key#)

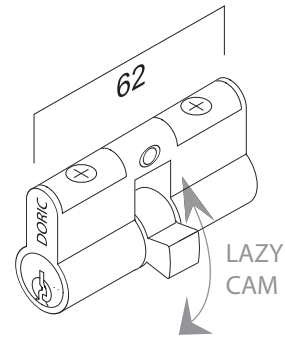

USED WITH



DS2075

DS2210

DS2220

DS2200

DS198 | EURO 46MM 6 WAFER CYLINDER

APPLICATION	Suits all sliding and swing door security locks
MATERIAL	Zinc
FINISHES	Chrome plated
CAM	Lazy/Floating
FIXINGS	Not included
KEYING	#270 ** - Includes 2 keys
ORDER CODE	MDS198 /(key#)

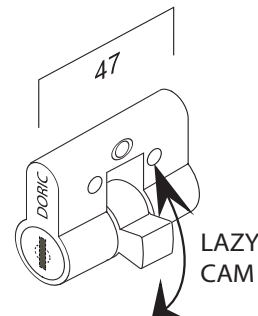

USED WITH



DS2075

DS2210

ACCESSORIES | SECURITY DOOR HARDWARE

DS2079/D | STAINLESS STEEL KEEPER

MATERIAL	Stainless steel
APPLICATION	Suits double doors
FIXINGS	No fittings
FINISH	Satin Stainless steel
ORDER CODE	9046495



DS2080 | EXTENDED STRIKER PLATE

MATERIAL	Stainless steel
EXTENDED HIP STRIKE	Suits DS2075
FINISH	Satin Stainless steel
ORDER CODE	9046697

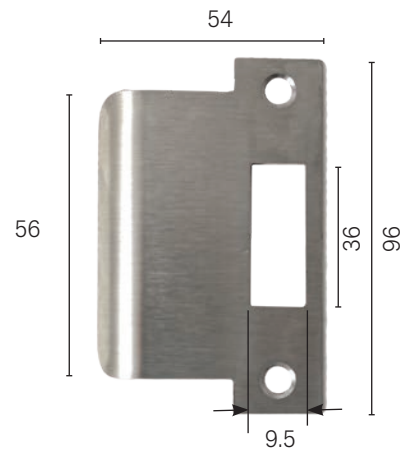

DS2081 | LOCK SHIELD

MATERIALS	Clear Acrylic
FIXINGS	Non required
THICKNESS	3mm



*Lock not included

ACCESSORIES | SECURITY DOOR HINGES

DH910 | HINGE PACKER

APPLICATION	DH10 & DH11
MATERIAL	Nylon
FINISH	Black mill
FIXINGS	Not included
ORDER CODE	9000160



DH10 | STEP-OVER SECURITY DOOR HINGE (WITH LUG)

APPLICATION	Aluminium extrusion security doors
MATERIAL	Mild steel
HINGED PIN	Mild steel
FINISH	Black, Primrose, Zinc plated, White
FIXINGS	8g screws (not included)
ORDER CODE	MDH10PC: Powder coated - nominate colour MDH10ZN: Zinc Plate

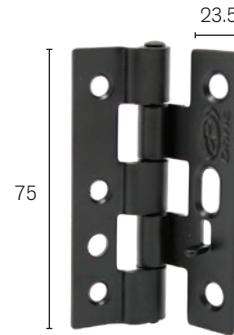

DH11 | STEP-OVER SECURITY DOOR HINGE

APPLICATION	Aluminium extrusion security doors
MATERIAL	Mild steel
HINGED PIN	Mild steel
FINISH	Black, primrose, zinc plated, white
FIXINGS	8g screws (not included)
ORDER CODE	MDH11PC: Powder coated - nominate colour MDH11ZN: Zinc Plate



DH11SS | STEP-OVER SECURITY DOOR HINGE

APPLICATION	Aluminium extrusion security doors
MATERIAL	Stainless steel 316
HINGED PIN	Stainless steel 316
FINISH	Satin Stainless steel
FIXINGS	8g screws (not included)
ORDER CODE	9003279TE

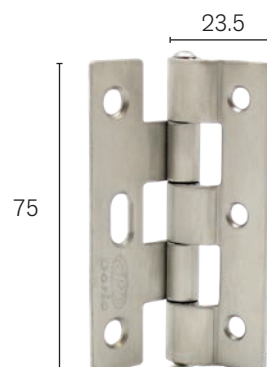

ACCESSORIES | SLIDING SECURITY DOOR HARDWARE

DR234/N | SECURITY DOOR ROLLER - SPRING LOADED - HOLD BACK

MATERIAL	Engineered plastic, zinc plated screw & zinc nut
-----------------	--



WHEEL	ORDER CODE	WEIGHT RATING
DR64	9047909	25kg max load

DR234/SL/64 | SECURITY DOOR ROLLER - SPRING LOADED

MATERIAL	Engineered plastic, zinc plated screw
-----------------	---------------------------------------



WHEEL	ORDER CODE	WEIGHT RATING
DR64	9012698	25kg max load

DS207 | SECURITY DOOR CORNER STAKE

MATERIAL	Glass filled nylon
ORDER CODE	9000156

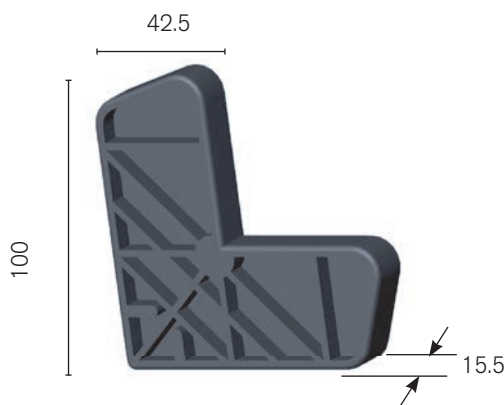

DS297 | SLIDING DOOR STOPPER

MATERIAL	PVC
FINISH	Black
FIXING	8G screw required Screw not included
ORDER CODE	9000224

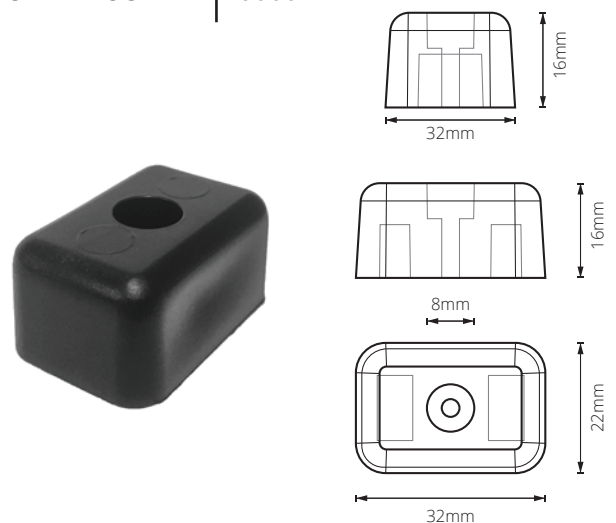

ACCESSORIES | FLY DOOR HARDWARE

DS141/N | 4 LITE FLY DOOR LATCH SET

FINISH	Black Mill
INCLUSIONS	1x Internal Handles 3 x External Handles 1 x Keeper
FIXINGS	6g screws (included)
ORDER CODE	9038749

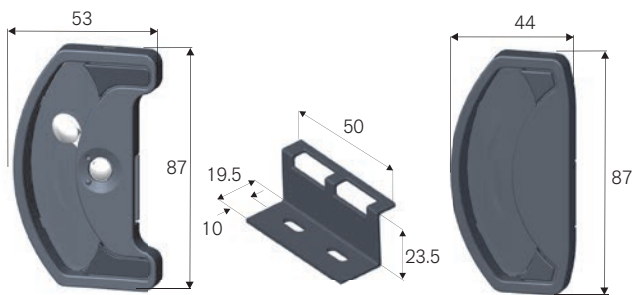

DS153/N | FLY DOOR LATCH SET

FINISH	Black Mill
INCLUSIONS	1 x Internal Handle 1 x External Handle 1 x Keeper
FIXINGS	6g screws (included)
ORDER CODE	9034368

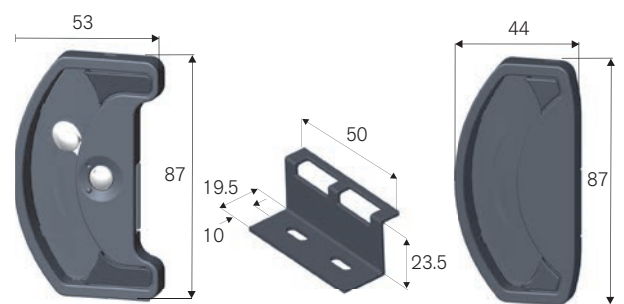

DS161/N | 4 LITE FLY DOOR LATCH SET

FINISH	Black Mill
INCLUSIONS	1 x Internal Handles 3 x External Handles 1 x Keeper
FIXINGS	6g screws (included)
ORDER CODE	9034369

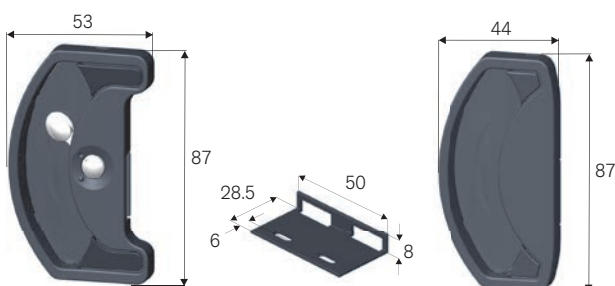

DS171/N | FLY DOOR LATCH SET

FINISH	Black Mill
INCLUSIONS	1 x Internal Handle 1 x External Handle 1 x Keeper
FIXINGS	6g screws (included)
ORDER CODE	9034370

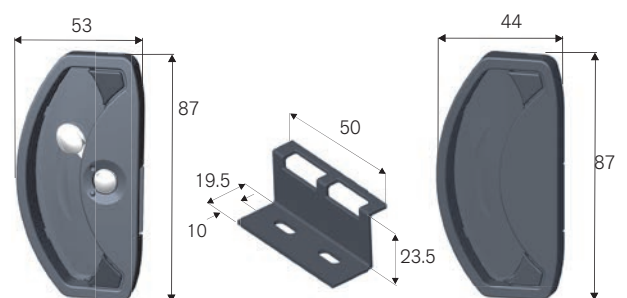

ACCESSORIES | FLY DOOR HARDWARE

DS106 | FLY DOOR KEEPER

APPLICATION	Suits Flyscreen Latches
MATERIAL	Steel
FINISHES	Black Powder coat
FIXINGS	6g screws (not included)
ORDER CODE	MDS106

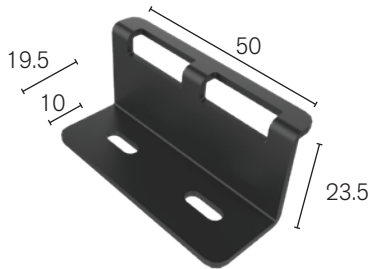

DS108 | FLY DOOR KEEPER

APPLICATION	Suits Flyscreen Latches
MATERIAL	Steel
FINISHES	Black Powder coat
FIXINGS	6g screws (not included)
ORDER CODE	MDS108

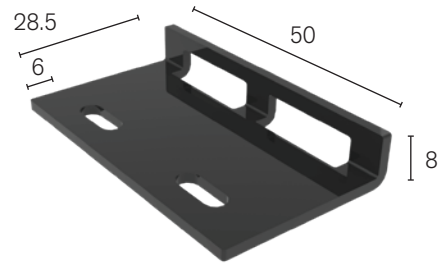

DS241 | FLY DOOR KEEPER

MATERIAL	Stainless steel
FIXINGS	6g screw (not included)
ORDER CODE	9000191 - Mill finish 9016165 - Black

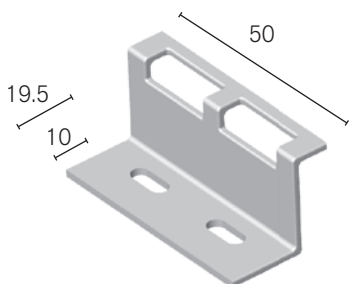

DS243 | FLY DOOR KEEPER

MATERIAL	Stainless steel
FIXINGS	6g screw (not included)
ORDER CODE	Referenced part. Not for individual sale.

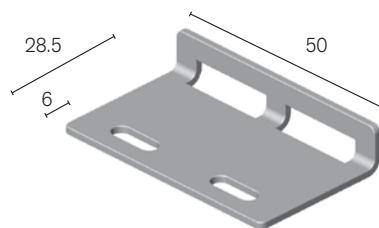

DS244 | FLY DOOR KEEPER

MATERIAL	Stainless steel
FIXINGS	6g screw (not included)
ORDER CODE	Referenced part. Not for individual sale.

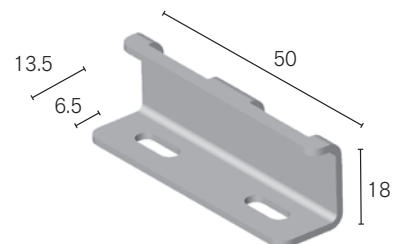

ACCESSORIES | FLY DOOR HARDWARE

DS274 | MAGNETIC SCREEN DOOR LATCH SET

MATERIAL	Engineered Plastic
FINISH	Black Moulded
APPLICATION	2 Lite Latch Set
INCLUSIONS	1 x Internal Handle 1 x External Handle 1 x Small Keeper Screws and cover caps
ORDER CODE	9047806

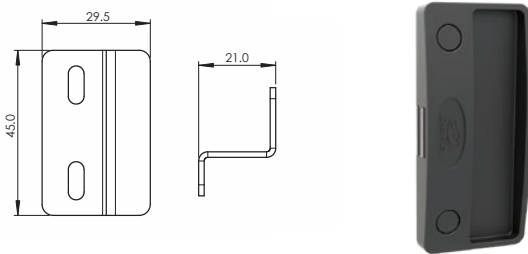

DS275 | MAGNETIC SCREEN DOOR LATCH SET

MATERIAL	Engineered Plastic
FINISH	Black Moulded
APPLICATION	4 Lite Latch Set
INCLUSIONS	1 x Internal Handles 3 x External Handles 1 x L Keeper Screws and cover caps
ORDER CODE	9047808

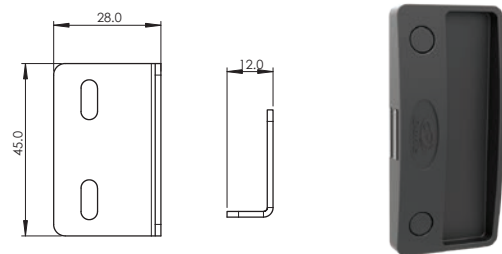

DS276 | MAGNETIC SCREEN DOOR LATCH SET

MATERIAL	Engineered Plastic
FINISH	Black Moulded
APPLICATION	2 Lite Latch Set suits Timber
INCLUSIONS	1 x Internal Handle 1 x External Handle 1 x Flat Keeper Screws and cover caps
ORDER CODE	9047810

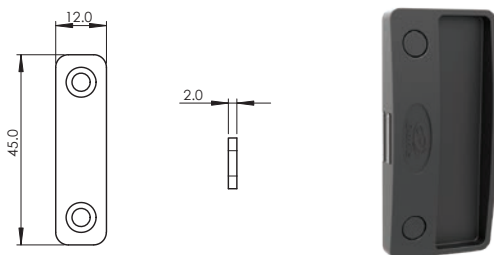

DS277 | MAGNETIC SCREEN DOOR LATCH SET

MATERIAL	Engineered Plastic
FINISH	Black Moulded
APPLICATION	2 Lite Latch Set
INCLUSIONS	1 x Internal Handle 1 x External Handle 1 x Large Z Keeper Screws and cover caps
ORDER CODE	9047812

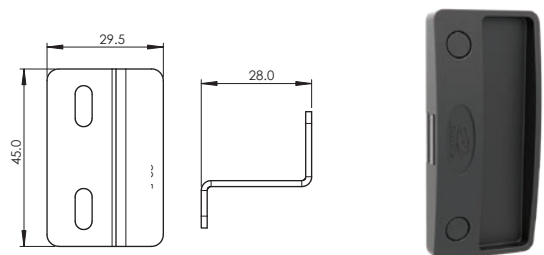

ACCESSORIES | FLY DOOR HARDWARE

DR339 | ADJUSTABLE FLYSCREEN DOOR CORNER STAKE WITH ROLLER

MATERIAL	Engineered plastic
-----------------	--------------------

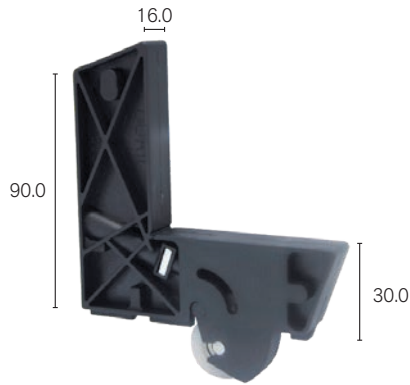

ROLLER	WHEEL	ORDER CODE	WEIGHT RATING
Standard	DR34	9002143	20kg max load

DR340 | ADJUSTABLE SECURITY DOOR CORNER STAKE WITH ROLLER

MATERIAL	Engineered plastic
-----------------	--------------------

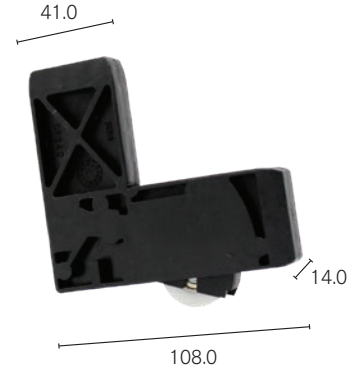

ROLLER	WHEEL	ORDER CODE	WEIGHT RATING
Standard	DR6	9002145	20kg max load

DR353 | DOOR GUIDE

APPLICATION	Sliding Barrier Doors
MATERIAL	Nylon
FINISH	Mill Black
FIXINGS	6g screw (not included)



DS530 | FLY DOOR SECURITY DOOR GUIDE

MATERIAL	Nylon
APPLICATION	Screen Security Door
ORDER CODE	9005565



ACCESSORIES | FLY DOOR HARDWARE

DS130 | FLY DOOR HANDLE

FINISH	Black mill
ORDER CODE	9000095MF



DS337 | FLY DOOR CLIP

MATERIAL	Nylon 66
FINISHES	Black mill
ORDER CODE	9000273

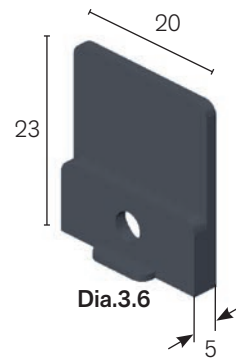

DS377 | SPACER BUTTON

APPLICATION	Sliding Security/Barrier Doors
MATERIAL	Nylon
FINISH	Mill Black



DS348 | FLAT SPACE BUTTON

MATERIAL	Nylon
APPLICATION	Sliding Doors
ORDER CODE	9000284



ACCESSORIES | FLYSCREEN HARDWARE

DS112 | FLYSCREEN PLUNGER CLIP

APPLICATION	Retainer system for flyscreen
MATERIAL	Engineered plastic
FINISHES	Black Mill
FIXINGS	Rivets (not included)
ORDER CODE	9003157 - White 9002692 - Brown 9000075 - Black

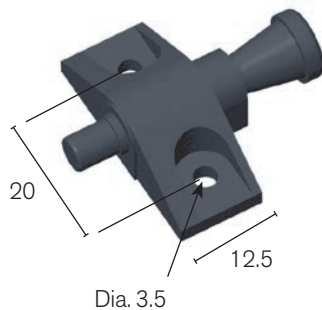

DS113 | FLYSCREEN PLUNGER CLIP

APPLICATION	Retainer system for flyscreen
MATERIAL	Engineered plastic
FINISHES	Black Mill
FIXINGS	Rivets (not included)
ORDER CODE	9000076

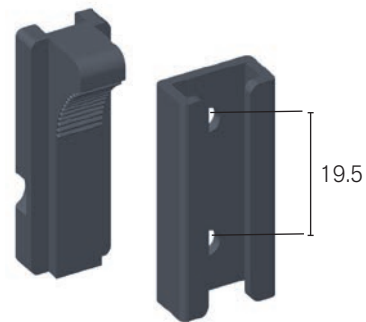

DS120 | FLYSCREEN LIFT TAB

APPLICATION	Suits 25mm x 11mm flyscreen frame for windows
MATERIAL	Polypropylene
FINISHES	Black Mill
ORDER CODE	9000084

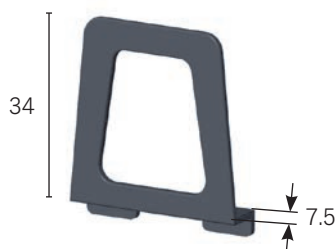

DS121 | FLYSCREEN LIFT TAB

APPLICATION	Suits 22mm x 9mm flyscreen frame for windows
MATERIAL	Polypropylene
FINISHES	Black Mill
ORDER CODE	9000085

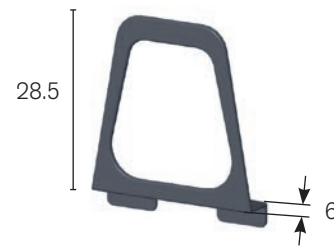

ACCESSORIES | FLYSCREEN HARDWARE

DS132 | FLYSCREEN SPRING CLIP

APPLICATION	Suits 22mm x 9mm flyscreen frame for windows
MATERIAL	Polypropylene
FINISHES	Black Mill
ORDER CODE	9000097

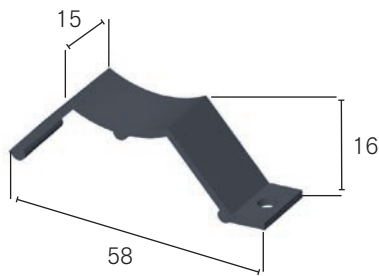

DS134 | FLYSCREEN LIFT TAB & PLUNGER

APPLICATION	Flyscreen
MATERIAL	Engineered plastic
FINISHES	Black Mill
FIXINGS	6g screws (not included)
ORDER CODE	9026037

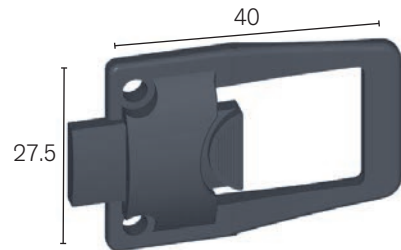

DS144 | FLYSCREEN SPRING

MATERIAL	Acetal natural (w/- black master batch)
FINISHES	Black Mill
ORDER CODE	9000109

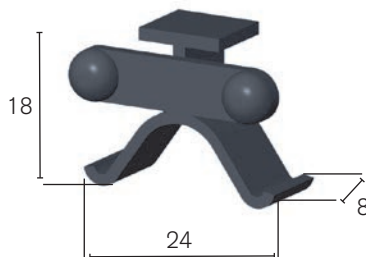

FLYSCREEN | PIVOT CLIP

MATERIAL	Nylon 6
FINISHES	Black Mill or Clear

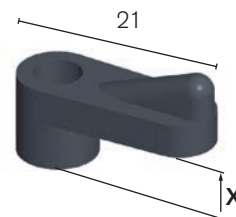

CODE	(X) SIZE	COLOUR	ORDER CODE
DS158	4mm	Black Clear	9000123 9025470
DS159	11.5mm	Black Clear	9000124 9051782
DS160	10mm	Black Clear	9000125 9035846
DS163	1.6mm	Black	9044415

ACCESSORIES | FLYSCREEN HARDWARE

DS162 | FLYSCREEN SPRING LOADED CLIP

MATERIAL	Clip - ABS, Spring - steel
FINISHES	Black Mill
ORDER CODE	9000127
MIN. ORDER	Qty: 4000 (non-stocked item)

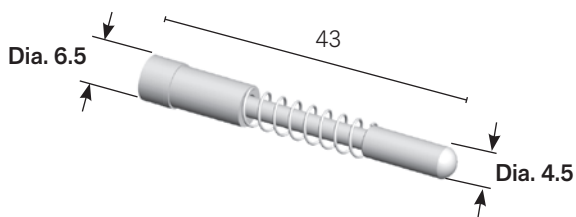

DS252 | FLY DOOR TENSIONER

MATERIAL	Engineered plastic
FINISHES	Black mill
FIXINGS	6g screw (not included)
ORDER CODE	9000202

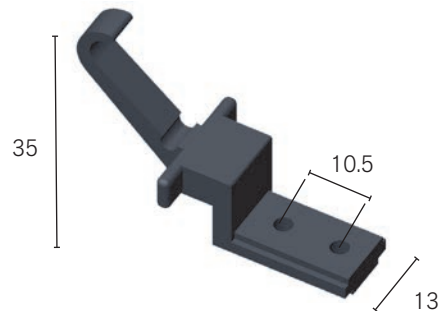

DS355 | FLYSCREEN CLIP

MATERIAL	Stainless steel
ORDER CODE	9000297

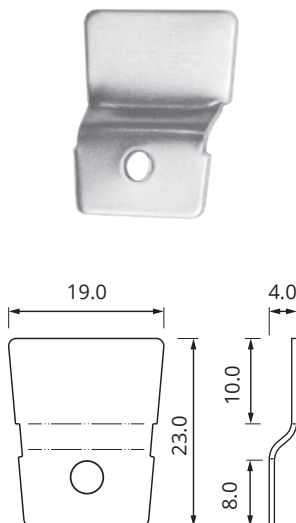

DS372 | FLYSCREEN CORNER STAKE

APPLICATION	Suits 25mm x 11mm flyscreen frame for windows
MATERIAL	High impact polystyrene
FINISHES	Black mill
ORDER CODE	9000308

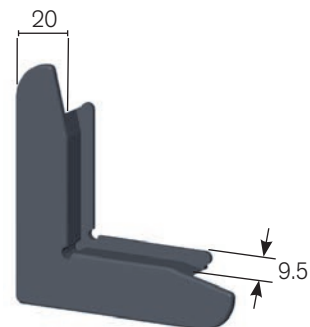

FRINGE PILE | SECURITY DOOR HARDWARE

DP13 | FRINGE

MATERIAL	Polypropylene siliconised yarn
COLOUR	Black
PILE HEIGHT	13mm
ORDER CODE	9004817

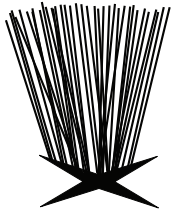

DP16 | FRINGE

MATERIAL	Polypropylene siliconised yarn
COLOUR	Black
PILE HEIGHT	16mm
ORDER CODE	9004818

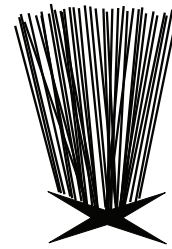

DP28 | FRINGE

MATERIAL	Polypropylene siliconised yarn
COLOUR	Black
PILE HEIGHT	28mm
ORDER CODE	9005076

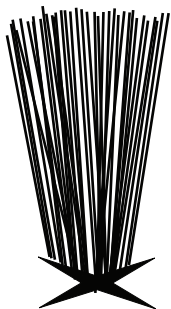

SECURITY MESH | SECURITY DOOR HARDWARE



Doric's range of Security Mesh offer class leading performance driven barrier screening designed to live against harsh outdoor weather, and withstand intrusion attempts, keeping families, homes and businesses safe.

Our meshes have been rigorously tested:

DYNAMIC IMPACT

Intruders relying on brute force and severe impact to invade your home will find themselves defeated by the patented two-part strengthening system of our superior doors. The robust Stainless steel mesh screen and aluminium panel work together to create a barrier that absorbs and spreads the shock of severe force, keeping you and your home secure.

PULL & JEMMY

There's more than just an aesthetic appeal in the powder coated mesh and fused decorative panel elements. The combination of structural strength along with a concealed snap aluminium beading creates a single impenetrable barrier, which protects the frame from jemmying and thwarts pulling and tugging attempts.

PROBE, KNIFE & SHEAR

Sharp implements and slicing tools are no match for the incredible strength of Doric premium mesh while the mesh has been designed to resist shearing, impact and slicing, it won't hamper air flow giving your home both vital protection and the fresh breezes it deserves.

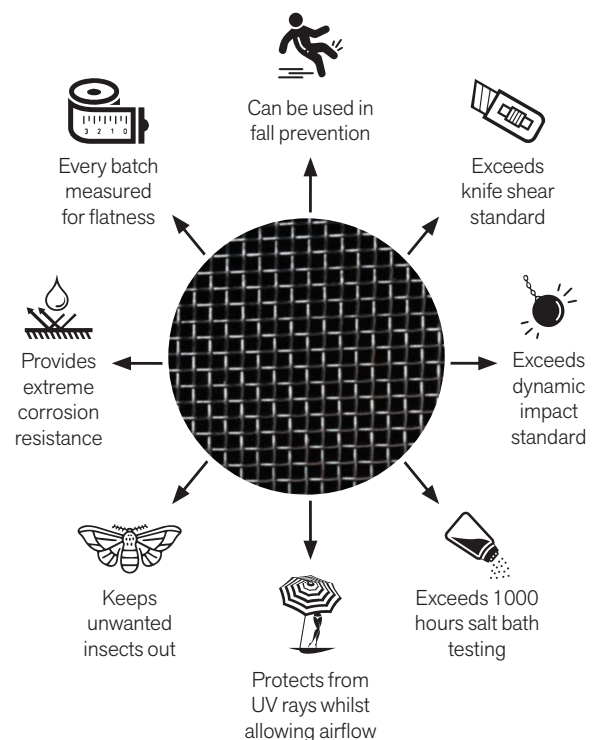

SECURITY MESH | SECURITY DOOR HARDWARE

SP67 | PUNCHED MESH

MATERIAL	Aluminium
FINISH	Black (standard) Custom colours (on request)
SIZES	750mm x 2000mm 900mm x 2000mm 1200mm x 2000mm 750mm x 2400mm 900mm x 2400mm 1200mm x 2400mm

Punched Mesh offers a flush premium security facade for entrance doors. Manufactured from aluminium ensures the Punched Mesh will have excellent corrosion resistance.

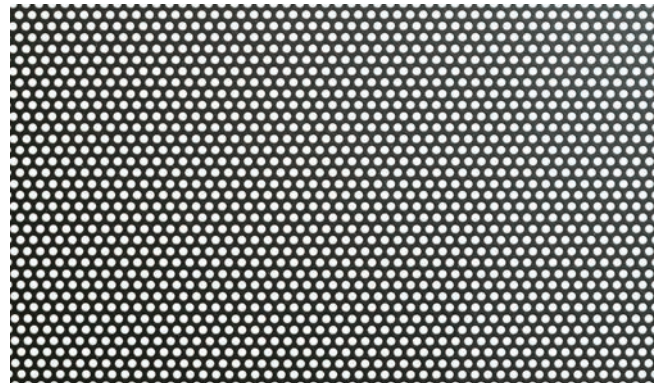

SP70 | GALVANISED MESH

MATERIAL	Steel
FINISH	Black (standard) Custom colours (on request)
SIZES	750mm x 2000mm 900mm x 2000mm 1200mm x 2000mm 1500mm x 2000mm 750mm x 2400mm 900mm x 2400mm 1200mm x 2400mm 1500mm x 2400mm 1200mm x 3000mm

Galvanised Mesh has been manufactured from steel strand wire providing a strong security screen with galvanic protection.

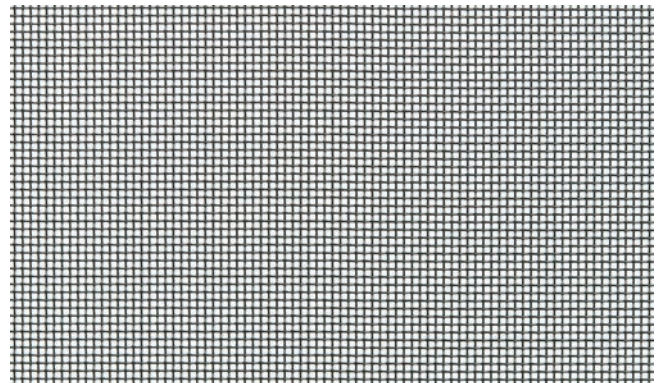

SP90 | RESTRICTED VIEW MESH

MATERIAL	Steel
FINISH	Black (standard) Custom colours (on request)
SIZES	750mm x 2000mm 900mm x 2000mm 1200mm x 2000mm 750mm x 2400mm 900mm x 2400mm 1200mm x 2400mm

Restricted View Mesh is manufactured from sheet steel and perforated to offer a strong security screen with one way vision.



CMESH | SP82 PREMIUM STAINLESS STEEL SECURITY MESH

CMesh is developed by fabricators for fabricators and is our 3rd generation of Stainless steel security mesh.

Developed and tested over 8 years, CMesh incorporates fabricator feedback to deliver a reliable and trusted, high quality product.

C MESH DIFFERENCE

- Every batch is tested for flatness (less than 2mm per m²) and knife shear tested
- Every batch measured for squareness to +/- 5mm over 2.4m x 1.2m sheet
- Minimum 1000 hours salt bath tested
- Every batch LMATS material analysis approved

TESTING

- Tested for flatness and squareness
- Passed against Jemmying Test for forced entry
- Passed Impact Test under AS5039-2008 for force impact attack type
- Passed Knife Shear Test under AS5039-2008 for sharp object penetration attack type
- Salt bath tested exceeding 1000 hours displaying extreme corrosion resistance

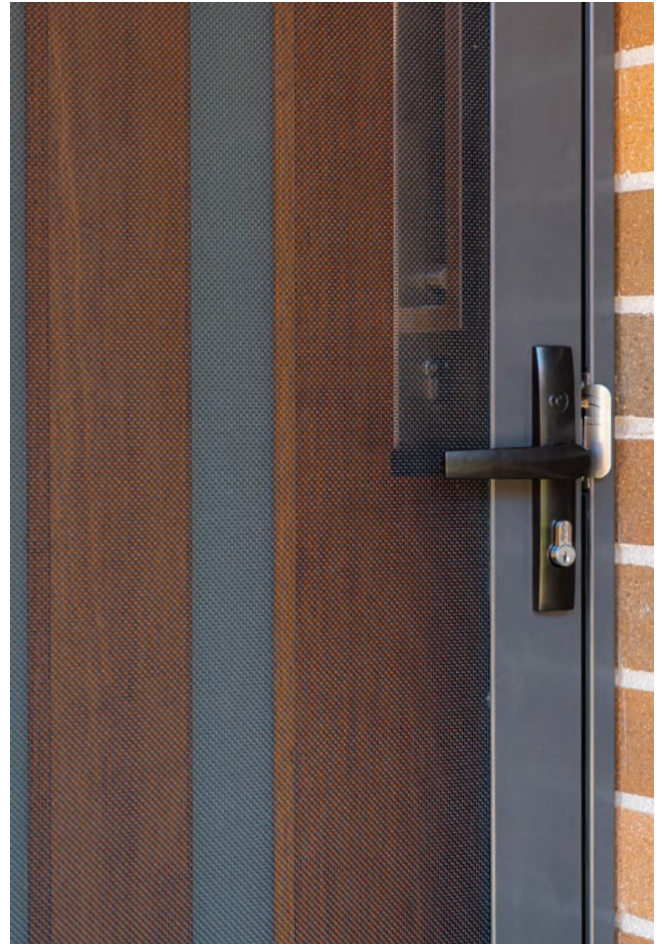

HOW TO ORDER

CODE	PRODUCT	SIZE	GRADE
9051132	SP82 CMesh	2400 x 900	316 SS
9051133	SP82 CMesh	2400 x 750	316 SS
9051134	SP82 CMesh	2000 x 1200	316 SS
9051135	SP82 CMesh	2400 x 1200	316 SS
9051184	SP82 CMesh	2000 x 900	316 SS
9051416	SP82 CMesh	2400 x 750	316 SS
9051417	SP82 CMesh	1500 x 1200	316 SS
9051765	SP82 CMesh	2400 x 1500	316 SS
9051766	SP82 CMesh	1200 x 900	316 SS

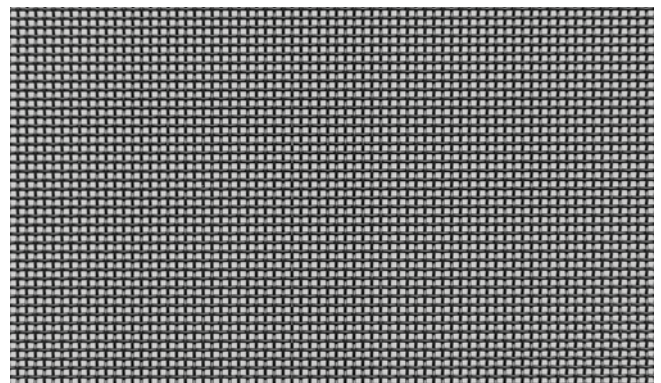

COLOURS



BLACK

INSECT SCREEN | BARRIER DOOR HARDWARE

FIBREGLASS | INSECT SCREEN

Simple installation with good visibility.

- Will not dent
- PVC coated Fibreglass yarn



PRODUCT DETAILS

MATERIAL	Fibreglass yarn
DIAMETER	0.27mm
WEAVE	18 x 14 per Sq Inch
OPEN AREA	69%
APERTURE	2.01mm ²
MANUFACTURE	Woven
EDGE	Raw edge
FINISH	PVC coated
COLOUR	Charcoal

HOW TO ORDER

PRODUCT CODE	BULK ROLL SIZES
SP105	610mm x 50m Fibreglass Bulk Roll
SP106	760mm x 50m Fibreglass Bulk Roll
SP107	810mm x 50m Fibreglass Bulk Roll
SP108	910mm x 50m Fibreglass Bulk Roll
SP109	1220mm x 50m Fibreglass Bulk Roll

ALUMINIUM | INSECT SCREEN

Resists harsh weather conditions

- Heavy duty alloy
- Powder coated mesh

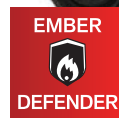

PRODUCT DETAILS

MATERIAL	Aluminium wire
DIAMETER	0.23mm
WEAVE	18 x 16 per Sq Inch
OPEN AREA	72%
APERTURE	1.81mm ²
MANUFACTURE	Woven
EDGE	Closed edge
FINISH	Powder coated
COLOUR	Charcoal
FIRE RATING	Up to BAL-29

HOW TO ORDER

PRODUCT CODE	BULK ROLL SIZES
SP100	610mm x 30m Aluminium Bulk Roll
SP101	760mm x 30m Aluminium Bulk Roll
SP102	810mm x 30m Aluminium Bulk Roll
SP103	910mm x 30m Aluminium Bulk Roll
SP104	1220mm x 30m Aluminium Bulk Roll

STAINLESS STEEL | INSECT SCREEN

Durable mesh that reduces glare

- Strong & Durable
- 316 Marine Grade SS

PRODUCT DETAILS

MATERIAL	Stainless steel wire
DIAMETER	0.18mm
WEAVE	18 x 16 per Sq Inch
OPEN AREA	77%
APERTURE	1.96mm ²
MANUFACTURE	Woven
EDGE	Raw edge
FINISH	Powder coated
COLOUR	Charcoal
FIRE RATING	Up to BAL-FZ

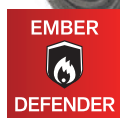
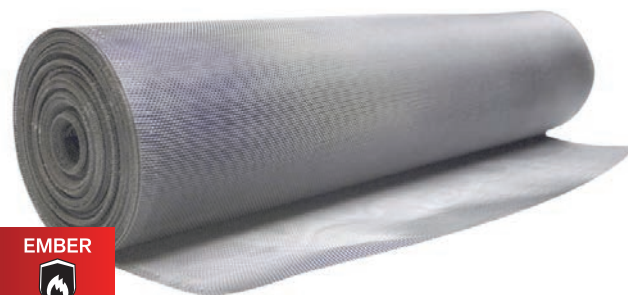

HOW TO ORDER

PRODUCT CODE	BULK ROLL SIZES
SP110	910mm x 30m Stainless steel Bulk Roll
SP111	1220mm x 30m Stainless steel Bulk Roll

SEE IT ON THE
screenview app
cowdroy



SP112 | RUBBER SPLINE 4.5mm – 300M ROLL

SUIT	Aluminium Screen
MATERIAL	PVC Rubber
COLOUR	Charcoal
DIAMETER	4.5mm
ROLL LENGTH	600m
ORDER CODE	SP112

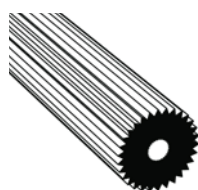

SP113 | RUBBER SPLINE 6mm – 300M ROLL

SUIT	Fibreglass screen
MATERIAL	PVC Rubber
COLOUR	Charcoal
DIAMETER	6mm
ROLL LENGTH	600m
ORDER CODE	SP113

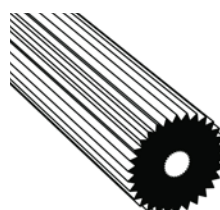

COLONIAL CAST PANELS | SECURITY & BARRIER DOOR HARDWARE

Colonial Cast Panels are manufactured from cast aluminium and powder coated to offer a longevity of such value that it will last decades longer than good taste allows.

Panels are in two sections, top (A) and bottom (B)

All panels have a wide selection of powder coat colour options available, along with large variety of panel styles on offer adds an even greater choice available.

DECORATIVE GLASS INSERTS

Cast panel design offering a selection of glass panes.

COLOURED INSERTS

Single coloured inserts are fixed into the panel and offer a range of colours.

COLONIAL CLASSIC DESIGN

Timeless designs featuring decorative cast styles.

FLOATING DECORATIVE GRILLES

Mounted on Doric's aluminium SP67 Punch Mesh, these cast panels are available ready for door frame fitment.

READING MEASUREMENTS

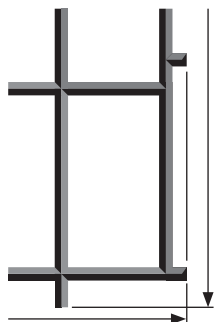

With Lugs

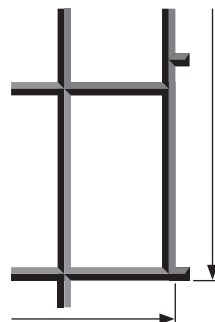

With Out Lugs

ORDERING EXPLAINER

SP13AB | Arch

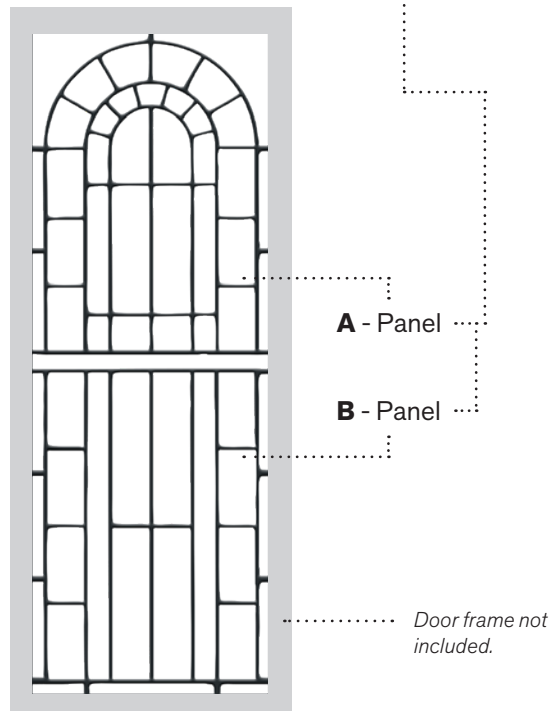
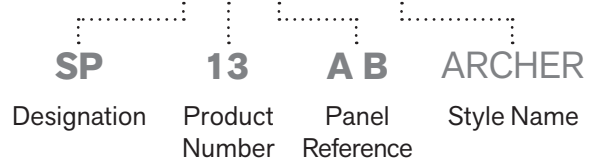

COLOUR OPTIONS

DORIC STANDARD POWDER COAT COLOUR RANGE

Panels available in Mill Finish, Standard Powder coat & Non-Standard Powder coat colours.

SATIN BLACK	PEARL WHITE	PRIMROSE	MONUMENT	CUSTOM ON REQUEST
WOODLAND GREY	CHARCOAL SATIN	BIRCH WHITE	BROWN	MARINO/PAPERBARK
OFF WHITE/SURFMIST	DEEP OCEAN	STONE BEIGE	HAWTHORN GREEN	SILVER
COLONIAL BRONZE	JASPER	CLARET	DUNE	APO GREY
				MAGNOLIA

HINGED DOOR | PANELS WITH DECORATIVE GLASS INSERTS

SP61AB



PANEL	WITH LUGS Height x Width (mm)	WITH OUT LUGS Height x Width (mm)
A	1135 x 813	1055 x 620
B	694 x 813	615 x 620

ORDER CODE	GLASS INSERT	COLOUR
SP61A	Black Orchid Red Orchid Kookaburra Rose Jewel	Powder coat (See Colour Options)
SP61B		

SP62AB



PANEL	WITH LUGS Height x Width (mm)	WITH OUT LUGS Height x Width (mm)
A	1135 x 813	1055 x 620
B	694 x 813	615 x 620

ORDER CODE	GLASS INSERT	COLOUR
SP62A	Black Orchid Red Orchid Kookaburra Rose Jewel	Powder coat (See Colour Options)
SP62B		

DECORATIVE GLASS INSERTS

Available with SP61A and SP62A only.



Black Orchid



Red Orchid



Kookaburra



Rose Jewel

HINGED DOOR | PANELS WITH COLOURED INSERTS

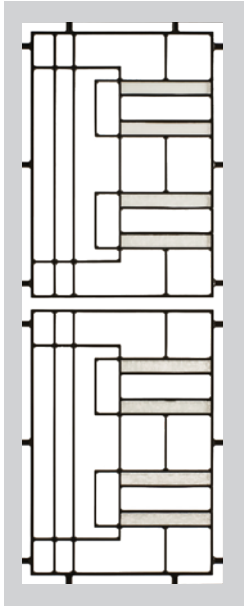

SP65AB

With Coloured Glass Inserts

PANEL	WITH LUGS Height x Width (mm)	WITH OUT LUGS Height x Width (mm)
A	1033 x 813	961 x 620
B	970 x 813	900 x 620

ORDER CODE	GLASS INSERT	COLOUR
SP65A	Teal Blue Rice Paper Olive Green	Powder coat (See Colour Options)
SP65B	Black	

COLOURED GLASS INSERTS

Colours are for illustrative purposes

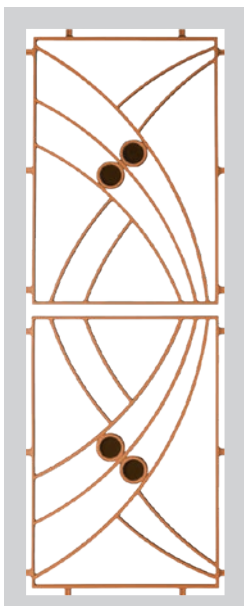

SP71AB | ART DECO

With Coloured Disc Inserts

PANEL	WITH LUGS Height x Width (mm)	WITH OUT LUGS Height x Width (mm)
A	967 x 812	898 x 620
B	967 x 812	898 x 620

ORDER CODE	DISC INSERT	COLOUR
SP71A	Bright Red Bistro Orange Satin Black	Powder coat (See Colour Options)
SP71B	French Blue Mountain Blue	

DISC INSERT COLOUR OPTIONS

Colours are for illustrative purposes



HINGED DOOR | COLONIAL CLASSIC DESIGN

SP14AB | FLOWER



PANEL	WITH LUGS Height x Width (mm)	WITH OUT LUGS Height x Width (mm)
A	1065 x 815	995 x 620
B	765 x 815	697 x 620

ORDER CODE	COLOUR
SP14A	Mill Finish
SP14B	Powder coat (See Colour Options)

SP18AB | FLOWER

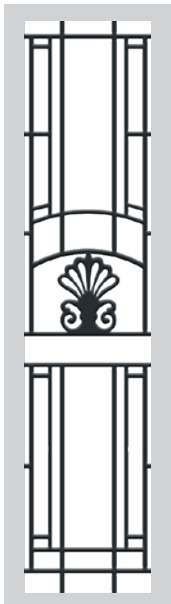

PANEL	WITH LUGS Height x Width (mm)	WITH OUT LUGS Height x Width (mm)
A	1065 x 500	995 x 385
B	765 x 500	697 x 385

ORDER CODE	COLOUR
SP18A	Mill Finish
SP18B	Powder coat (See Colour Options)

SP27AB | ARCHITRAVE

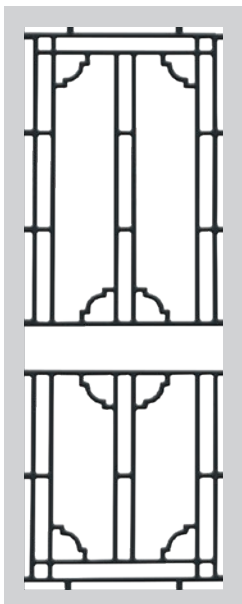

PANEL	WITH LUGS Height x Width (mm)	WITH OUT LUGS Height x Width (mm)
A	1046 x 813	994 x 620
B	750 x 813	698 x 620

ORDER CODE	COLOUR
SP27A	Mill Finish
SP27B	Powder coat (See Colour Options)

HINGED DOOR | COLONIAL CLASSIC DESIGN

SP17 | SEMI CIRCLE

2 per door

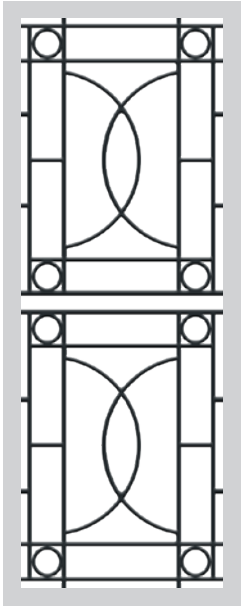

PANEL	WITH LUGS Height x Width (mm)	WITH OUT LUGS Height x Width (mm)
A/B	968 x 814	898 x 620

ORDER CODE	COLOUR
SP17	Mill Finish
	Powder coat <i>(See Colour Options)</i>

SP34AB | RECTANGLES

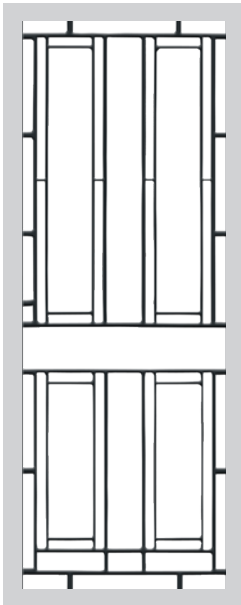

PANEL	WITH LUGS Height x Width (mm)	WITH OUT LUGS Height x Width (mm)
A	1062 x 813	990 x 620
B	762 x 813	690 x 620

ORDER CODE	COLOUR
SP34A	Mill Finish
SP34B	Powder coat <i>(See Colour Options)</i>

SP37AB | CROSS

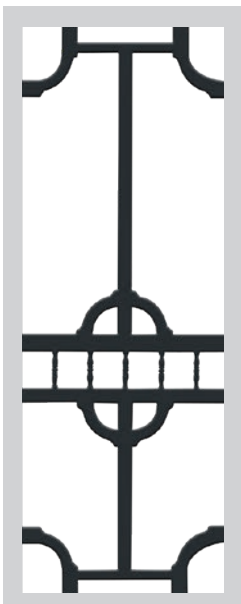

PANEL	WITH LUGS Height x Width (mm)	WITH OUT LUGS Height x Width (mm)
A	1089 x 813	- x 620
B	873 x 813	- x 620

ORDER CODE	COLOUR
SP37A	Mill Finish
SP37B	Powder coat <i>(See Colour Options)</i>

HINGED DOOR | COLONIAL CLASSIC DESIGN

SP50AB | DOUBLE VINE

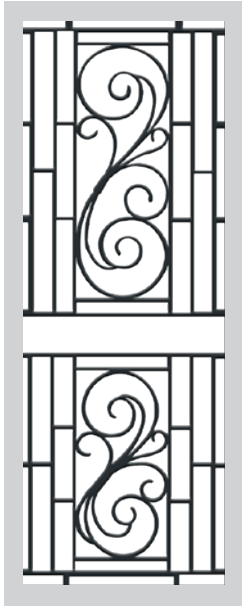

PANEL	WITH LUGS Height x Width (mm)	WITH OUT LUGS Height x Width (mm)
A	1035 x 814	967 x 620
B	816 x 814	744 x 620

ORDER CODE	COLOUR
SP50A	Mill Finish
SP50B	Powder coat (See Colour Options)

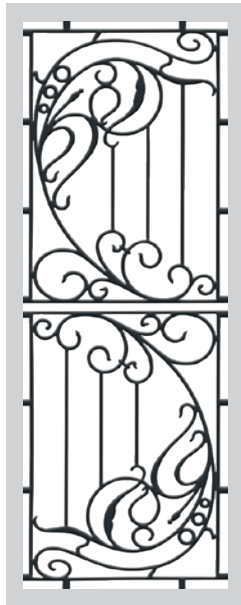
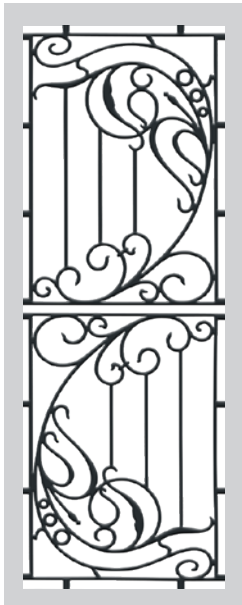

SP52AB | VINES

2 per door

SP53AB | VINES

2 per door

PANEL	WITH LUGS Height x Width (mm)	WITH OUT LUGS Height x Width (mm)
A / B	972 x 811	902 x 620

ORDER CODE	COLOUR
SP52A	Mill Finish
SP52B	Powder coat (See Colour Options)
SP53A	Mill Finish
SP53B	Powder coat (See Colour Options)

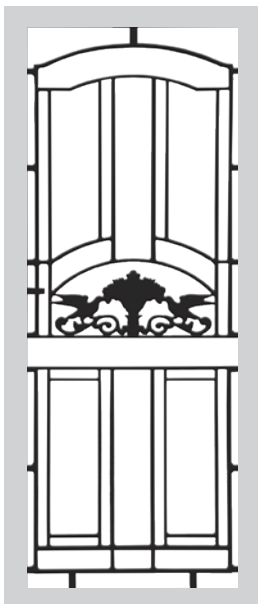

SP78AB | DOVES

PANEL	WITH LUGS Height x Width (mm)	WITH OUT LUGS Height x Width (mm)
A	1055 x 815	990 x 620
B	765 x 815	697 x 620

ORDER CODE	COLOUR
SP78A	Mill Finish
SP78B	Powder coat (See Colour Options)

HINGED DOOR | COLONIAL CLASSIC DESIGN

SP13AB | ARCH

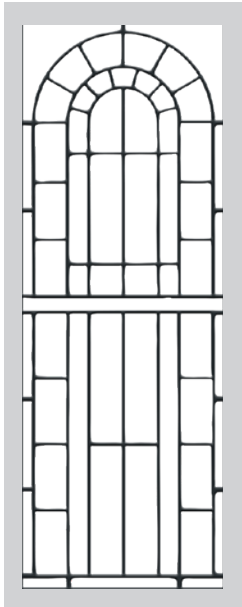

PANEL	WITH LUGS Height x Width (mm)	WITH OUT LUGS Height x Width (mm)
A	972 x 811	903 x 620
B	972 x 811	903 x 620

ORDER CODE	COLOUR
SP13A	Mill Finish
SP13B	Powder coat (See Colour Options)

SP13BB | RECTANGLES

2 per door

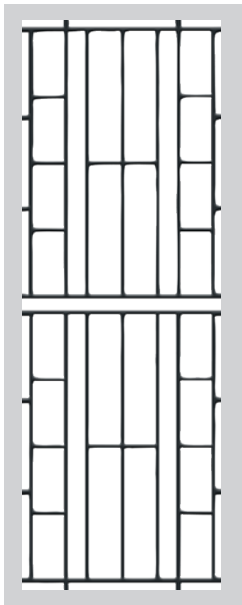

PANEL	WITH LUGS Height x Width (mm)	WITH OUT LUGS Height x Width (mm)
B / B	972 x 811	903 x 620

ORDER CODE	COLOUR
SP13BB	Mill Finish Powder coat (See Colour Options)

SP29AB | GATE

2 per door

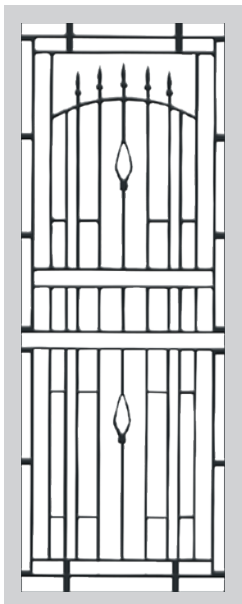

PANEL	WITH LUGS Height x Width (mm)	WITH OUT LUGS Height x Width (mm)
A	1066 x 813	995 x 620
B	884 x 813	773 x 620

ORDER CODE	COLOUR
SP29A	Mill Finish
SP29B	Powder coat (See Colour Options)

HINGED DOOR | COLONIAL CLASSIC DESIGN

SP44AB | CLASSIC

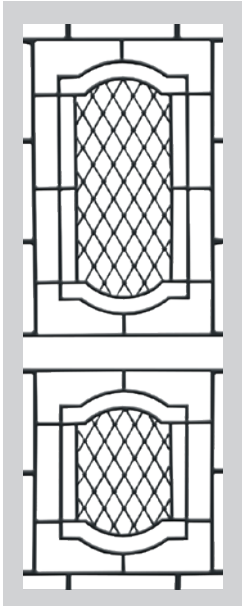

PANEL	WITH LUGS Height x Width (mm)	WITH OUT LUGS Height x Width (mm)
A	1074 x 813	1000 x 620
B	772 x 813	698 x 620

ORDER CODE	COLOUR
SP44A	Mill Finish
SP44B	Powder coat (See Colour Options)

SP51AB | DUAL ARCH

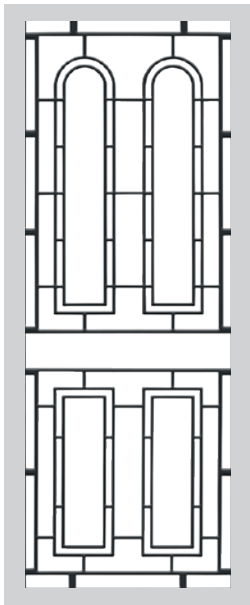

PANEL	WITH LUGS Height x Width (mm)	WITH OUT LUGS Height x Width (mm)
A	1065 x 813	996 x 620
B	766 x 813	697 x 620

ORDER CODE	COLOUR
SP51A	Mill Finish
SP51B	Powder coat (See Colour Options)

SLIDING DOOR | COLONIAL CLASSIC DESIGN

SP15BB | RECTANGLES

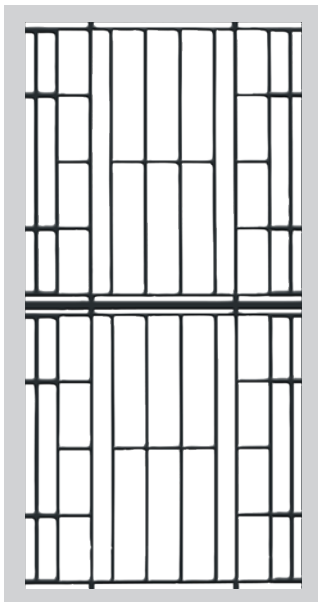

PANEL	WITH LUGS Height x Width (mm)	WITH OUT LUGS Height x Width (mm)
B/B	1016 x 1100	964 x 998

ORDER CODE	COLOUR
SP15BB	Mill Finish Powder coat (See Colour Options)

HINGED DOOR | COLONIAL CLASSIC DESIGN

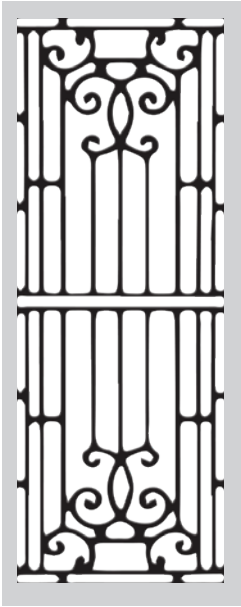

SP55 | CURLY

2 per door

PANEL	WITH LUGS Height x Width (mm)	WITH OUT LUGS Height x Width (mm)
A / B	967 x 813	901 x 620

ORDER CODE	COLOUR
SP55	Mill Finish
	Powder coat <i>(See Colour Options)</i>

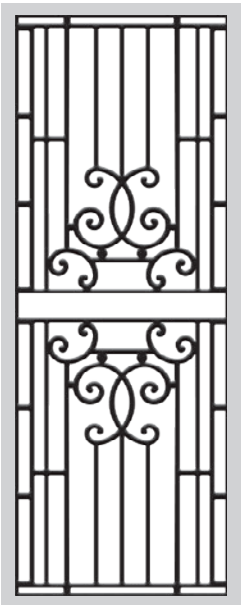

SP56 | CURLY

2 per door

PANEL	WITH LUGS Height x Width (mm)	WITH OUT LUGS Height x Width (mm)
A / B	967 x 813	901 x 620

ORDER CODE	COLOUR
SP56	Mill Finish
	Powder coat <i>(See Colour Options)</i>

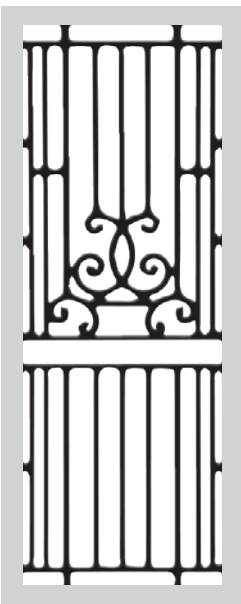

SP57AB | CURLY

PANEL	WITH LUGS Height x Width (mm)	WITH OUT LUGS Height x Width (mm)
A	1067 x 813	995 x 620
B	771 x 813	700 x 620

ORDER CODE	COLOUR
SP57A	Mill Finish
SP57B	Powder coat <i>(See Colour Options)</i>

HINGED DOOR | FLOATING DECORATIVE PANELS ON MESH

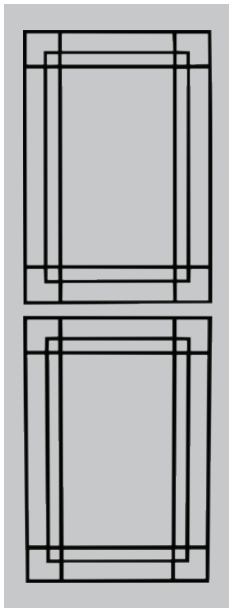

SP67 750x2000

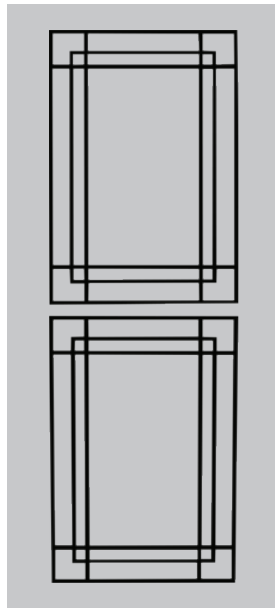

SP67 900x2000

SP72

Panels are centre mounted on Doric's aluminium SP67 Punch Mesh with a fixed 35mm vertical gap between panels.

PANEL	WITH OUT LUGS	
	Height x Width (mm)	
A / B	895	625
(Gap)	35	
Total	1825 x 625	

ORDER CODE	COLOUR	CMESH SIZES
SP72	Powder coat (See Colour Options)	SP67 750x2000 SP67 900x2000

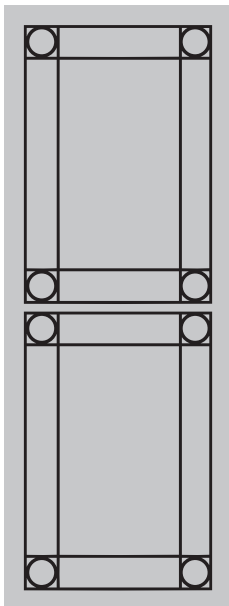

SP67 750x2000

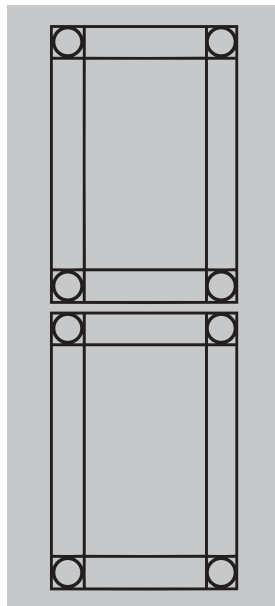

SP67 900x2000

SP73

Panels are centre mounted on Doric's aluminium SP67 Punch Mesh with a fixed 35mm vertical gap between panels.

PANEL	WITH OUT LUGS	
	Height x Width (mm)	
A / B	895	625
(Gap)	35	
Total	1825 x 625	

ORDER CODE	COLOUR	CMESH SIZES
SP73	Powder coat (See Colour Options)	SP67 750x2000 SP67 900x2000



SP67 750x2000



SP67 900x2000

SP74

Panels are centre mounted on Doric's aluminium SP67 Punch Mesh with a fixed 140mm vertical gap between panels.

PANEL	WITH OUT LUGS	
	Height x Width (mm)	
A	995	x 625
(Gap)	140	
B	700	x 625
Total	1535 x 625	

ORDER CODE	COLOUR	CMESH SIZES
SP74	Powder coat (See Colour Options)	SP67 750x2000 SP67 900x2000

INNOVATORS

OF HARDWARE FOR WINDOWS AND DOORS

Security and Barrier Doors Catalogue .v1.3-14.12.2022

SYDNEY

38 Redfern St,
Wetherill Park
Sydney, NSW 2164
Australia
Ph: +61 2 9609 2555
www.doric.com.au

AUCKLAND

26/C Triton Drive,
Albany, North Shore,
Auckland 0632
New Zealand
Ph: +64 9 415 5535
www.doric.co.nz

KUALA LUMPUR

No.17 Jalan 51/203A,
Kawasan Perindustrian Tiong Nam,
Seksyen 51, 46050 Petaling Jaya,
Selangor, Malaysia
Ph: +603 777 33 628
www.doric.com.my



**ALCHIN
LONG
GROUP**



SECURITY & BARRIER

HARDWARE
& ACCESSORIES