



DR2100

MULTI-PURPOSE MID-WEIGHT
ADAPTABLE ROLLER

A robust patio door roller adaptable for a range of residential and commercial doors.

The DR2100 roller is a multi-purpose patio door roller designed in Australia by Doric's engineering team to suit residential and commercial aluminium, timber and uPVC sliding doors in high performance capacity.

Manufactured with an engineered polymer outer carriage housing and high impact polymer inner carriage, this adjustable roller offers superior corrosion resistance and durability.

The DR2100 roller provides "ZZ" bearing performance rating and is moulded with a high performance engineered polymer that gives excellent load rating and cycle testing.

Additionally, the High Impact Polymer inner carriage has been designed to provide greater cover and protection to the wheels, helping avoid chipping and other damage occurring prior to installation.

PRODUCT DETAILS

OUTER CARRIAGE	Engineered polymer
INNER CARRIAGE	High impact polymer
TYRE	DR20 high performance polymer with "ZZ" bearing and dust seal.
FINISH AVAILABLE	Mill Finish Black
MAX LOAD CAPACITY	60kg per carriage

TESTING



CYCLIC TEST

Product operation tested to 30,000 cycles



SALT SPRAY TEST

Tested for corrosion resistance



ADVANTAGES



Suits aluminium, timber and uPVC sliding doors



Fully adjustable carriage gives 10mm height adjustment with Mild Steel Plated adjusting screw and nut



Outer carriage and internal assembly manufactured to withstand corrosive environments



High performance roller with corrosion resistant ground precision "ZZ" bearing



High impact polymer inner carriage designed to protect wheels and minimise damage prior to installation



Recommended for larger sliding doors up to 120kg



Unique multi-fit end caps



DIMENSIONS

DR2100-14

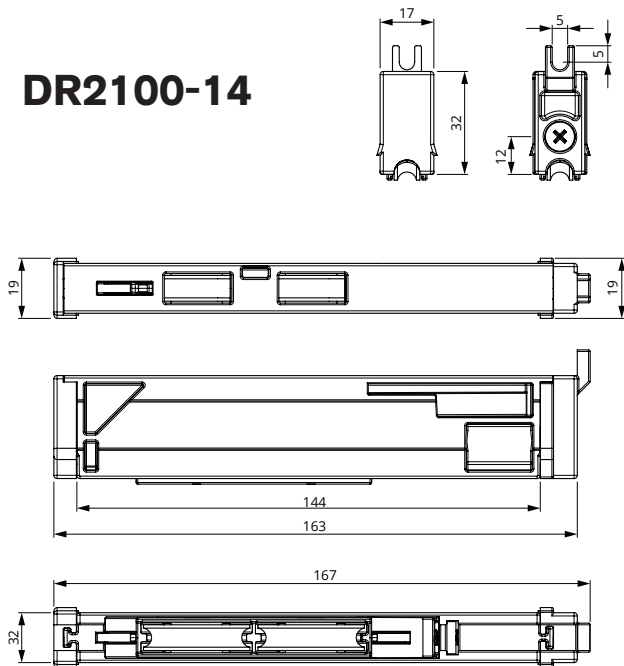

DR2100-17

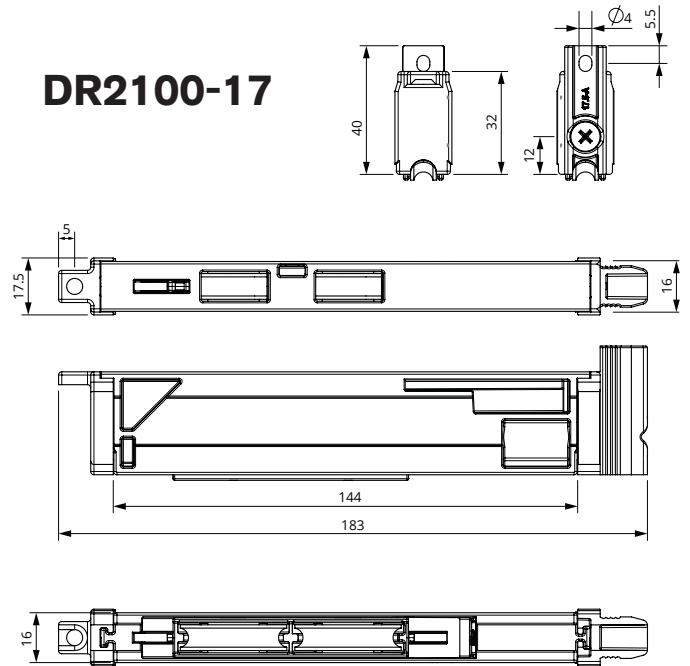

HOW TO ORDER

PRODUCT	END CAP	WHEEL	WEIGHT RATING	ORDER CODE
DR2100-14	14	DR20	60kg max load	9114440
DR2100-17	17	DR20	60kg max load	9114454

INNOVATORS

OF HARDWARE FOR WINDOWS AND DOORS

DR2100 Mid-Weight Door Roller 1.5 - 29/05/2024

SYDNEY

38 Redfern St,
Wetherill Park
Sydney, NSW 2164
Australia
Ph: +61 2 9609 2555
www.doric.com.au

AUCKLAND

26/C Triton Drive,
Albany, North Shore,
Auckland 0632
New Zealand
Ph: +64 9 415 5535
www.doric.co.nz

KUALA LUMPUR

Unit 6, Level 4, SetiaWalk Mall (*Block K*),
SetiaWalk, Persiaran Wawasan,
Pusat Bandar Puchong,
47160 Puchong, Selangor, Malaysia
Ph: +603 8602 2100
www.doric.com.my



DR2100

MULTI-PURPOSE MID-WEIGHT
ADAPTABLE ROLLER